

4 VESSELS & STIRRERS



QVF

PROCESS PLANT COMPONENTS

P 304 e.3



Copyright © 2007, QVF Engineering GmbH. All rights reserved.

Introduction

QVF vessels and stirrers provide the optimum solution for every requirement encountered in practice because of the wide range of types available. Vessels in either basic or jacketed form are essential components of many units and plants, both large and small. They can be combined with various components such as vessel covers, stirrers, stirrer drives and heat exchangers to construct a widely varying range of stirred units and reaction units. The range is supplemented by complete assemblies such as mobile vessels, horizontal separators and cyclones.

These components are widely used in the chemical, pharmaceutical and allied industries together with other applications such as food and drink production, dye works and electroplating. This is because of the special properties of borosilicate glass 3.3, glass-lined steel and PTFE (gaskets) plus the fact that borosilicate glass 3.3 is an approved and proven material of construction for pressure vessels.

Reference should also be made in this context to the extreme reliability of the strong and high-duty coupling system used for all components. This is achieved throughout the whole range of nominal sizes by the use of the safety buttress end which has been designed specifically by taking into account the properties of the material coupled with a reliable flange system.

The complete range of standard components and assemblies is described on the following pages. Non-standard components that can be supplied to special order are referred to in the respective product description.

A detailed listing of all components by »Description« and »Catalogue Reference« can be found in the »Index«.



Detailed information on a number of the topics referred to in the following pages can be found in Section 1 »Technical Information«.

Details of the design of the different types of optimised buttress ends are illustrated alongside.

Immersion heat exchangers for spherical and cylindrical vessels can be found in Section 5 »Heat Exchangers«.

GMP compliant installations

The use of vessels, stirrers and stirrer drives and the layout of interconnecting pipeline incorporating valves, when designing plant and equipment complying with GMP regulations, calls for special care in both the planning and selection of the components used together with the materials of construction used for them. Borosilicate glass 3.3 has a number of special properties that are highly valued in the pharmaceutical industry and these in conjunction with materials approved in accordance with the FDA catalogue, such as glass-lined steel (vessels, valves) and PTFE (bellows, lining, coating), ensure that any build-up of unwanted deposits is avoided in areas which come in contact with the product. A design without any dead space, which ensures that components drain fully and can be cleaned easily and effectively, is achieved by the shape of the components, the way they are installed and the selection of suitable valves. Where the external surfaces of complete assemblies have to comply with clean room requirements, appropriate stainless steel coupling and support material can be supplied (please see Section 9 »Couplings« and Section 10 »Structures and Supports«).

We would be happy to advise you on the basis of the regulatory requirements applicable to a particular case and the guidelines drawn up by us, for the design of GMP compliant plant.



DN15 - DN150



DN200 - DN300

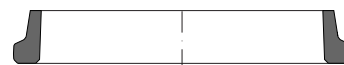

DN450 - DN1000

Coated vessels

Damage to borosilicate glass 3.3 vessels and vessel covers resulting from accidental external causes cannot be entirely excluded, especially in the smaller nominal sizes. This is primarily due to the relatively rigorous conditions prevalent in production plants and applies especially where no additional protection is provided in the form of insulation.

Our answer to this problem is to provide borosilicate glass 3.3 vessels with a Sectrans transparent coating. This can be applied irrespective of the shape of the component and it provides additional protection without having any adverse effect on visual monitoring of the process.

A glass fibre reinforced polyester coating providing a higher level of protection can also be supplied on request. This does have a slightly adverse effect on the transparency of the glass, making it translucent and not transparent.

Permissible operating conditions

While the maximum permissible operating temperature for borosilicate glass 3.3 vessels, vessel covers and fittings is generally 200 °C ($\Delta\theta \leq 180$ K), the maximum permissible operating pressure is governed by the main nominal size or the maximum diameter (spherical vessels only) of the component but not by its shape. Detailed information on this and the operation of jacketed components can be found in Section 1 »Technical Information«.

The permissible operating conditions for components in other materials can be found in the respective product description.



Glass components suitable for higher permissible operating conditions can be supplied on request.

SPHERICAL VESSELS

Spherical vessels are commonly used not only as simple receivers and feed vessels but also for stirred and reaction vessels as well as circulatory evaporators. Cylindrical vessels (please see page 4.9 to 4.12) can be used as a possible alternative as can jacketed glass-lined steel vessels as specified on pages 4.23 and 4.24.

Various items for use with spherical vessels can be found as follows: vessel covers and connection flanges for stirrer drives on pages 4.18 to 4.20 and 4.42 glass and metal immersion heat exchangers in Section 5 »Heat Exchangers«, heating mantles and heating baths on pages 4.31 to 4.33 and stirrers on page 4.35 onwards.

To cater for their wide variety of possible uses, spherical vessels are required with various bottom and side branches (the top branch cannot be varied for manufacturing reasons). The illustration alongside shows the variations that occur most frequently and the table below gives information about the range of possible side branch diameters.

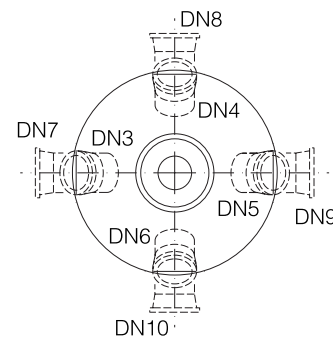
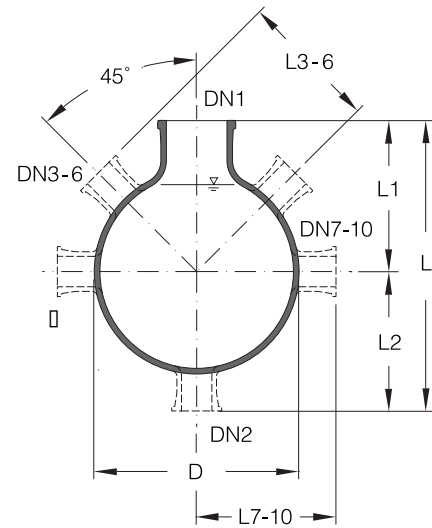

Nominal capacity (l)	D	DN1	DN2	DN3 : DN6	DN7 : DN10	L	L1	L2	L3 : L6	L7 : L10
10	280	100	15	15	15	430	250	180	180	180
				25	25	450		200	200	200
				40	40	455		205	205	205
				50	50	465		215	215	215
				80	80	475		225	225	225
				100	80	500		250	225	225
20	350	100	15	15	15	540	325	215	215	215
				25	25	560		235	235	235
				40	40	565		240	240	240
				50	50	575		250	250	250
				80	80	585		260	260	260
				100	80	610		285	260	285
50	490	200	25	25	25	705	400	305	305	305
				40	40	710		310	310	310
				50	50	720		320	320	320
				80	80	730		330	330	330
				100	100	755		355	355	355
				150	100	790		390	355	390
100	610	200	25	25	25	815	450	365	365	365
				40	40	825		375	370	370
				50	50	830		380	380	380
				80	80	840		390	390	390
				100	100	865		415	415	415
				150	150	900		450	450	450
200	750	300	25	25	25	985	550	435	435	435
				40	40	990		440	440	440
				50	50	1000		450	450	450
				80	80	1010		460	460	460
				100	100	1035		485	485	485
				150	150	1070		520	500	520
500	1005	450	50	-	-	-	-	-	-	-

SPHERICAL VESSELS

The versions described on pages 4.6 and 4.7 are available as standard. Details and dimensions, common to the various versions of vessels, can be found in the appropriate illustrations and tables.

All spherical vessels can be supplied with graduations on request.



If spherical vessels are to be delivered with a valve seat to serve a bottom outlet valve, its reference shall have additional designation. The dimension L extends in accordance with the following table.

For spherical vessels that are to be installed into bath-type heating vessels and are to be equipped with a valve seat for a bottom outlet valve »BAL40« (see Chapter 3 »Fittings«), the order reference shall then be supplemented by the letters »BAL«, e.g. »VSM..BAL«.

For spherical vessels without a sealed in for the bottom outlet valve, which are then deployed in a bath-type heating vessel, the reference is »VSM..E«. The supplement »E« stands for the necessary extended nozzle.

Nominal capacity (l)	DN2	L for VS...BAS	L for VS...BAL	L for VS...E
10	40	500	580	580
20	40	610	690	690
50	40	755	835	835
100	40	865	945	945
200	40	1035	1115	1115
500	40	1315	-	-

For a dead space free sealing with the use of a bottom outlet valve "BASD25" (see Chapter 3 "Fittings"), the spherical vessel may be equipped with a sealed in glass seat, as well as with an integrated drainage nozzle. Then the reference is, e.g. "VSM..BASD". Upon use of heating mantles "HHK or HHW", an accordingly longer nozzle shall be deployed for the drainage valve "BAMD25". Then the reference becomes, e.g. "VSM..BAMD".

Nominal capacity (l)	L for VS...BASD	L for VS...BAMD
10	540	590
20	650	700
50	790	840
100	900	950
200	1070	1120

SPHERICAL VESSELS

Receivers

Nominal capacity (l)	D	DN1	DN2	L	L1	Reference
10	280	100	40	455	250	VSC10
20	350	100	40	565	325	VSC20
50	490	200	40	710	400	VSC50
100	610	200	40	825	450	VSC100
200	750	300	50	1000	550	VSC200
500	1005	450	50	1300	700	VSC500

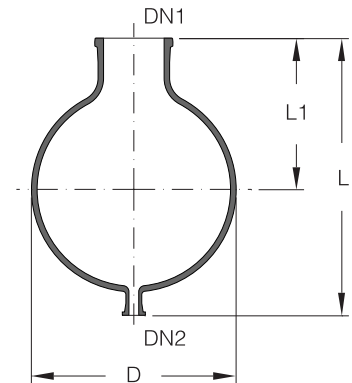

SPHERICAL VESSELS

Reaction Vessels

Nominal capacity (l)	D	DN1	DN2 DN3 DN5	DN4	DN6	L	L1	L3 L5	L4	L6	Reference
10	280	100	40	80	80	455	250	205	225	225	VSM10
20	350	100	40	80	80	565	325	240	260	260	VSM20
50	490	200	40	80	80	710	400	310	330	330	VSM50
100	610	200	40	100	100	825	450	370	415	415	VSM100
200	750	300	50	100	150	1000	550	450	485	500	VSM200

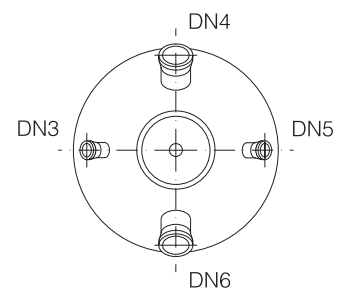
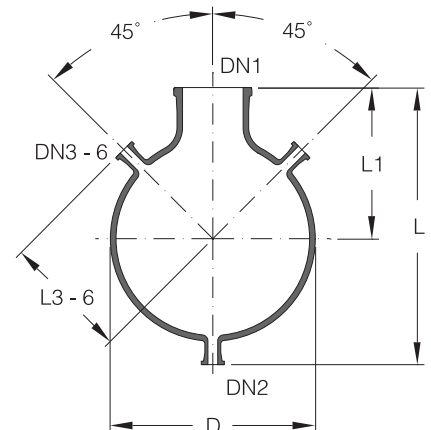

SPHERICAL VESSELS

Reaction Vessels for Immersion Heaters

Nominal capacity (l)	D	DN1	DN2	DN3 DN5	DN4	DN6	L	L1	L3 L5	L4	L6	Reference
10	280	100	150	40	80	80	535	250	205	225	225	VSH10
20	350	100	150	40	80	80	645	325	240	260	260	VSH20
50	490	200	200	40	80	80	775	400	310	330	330	VSH50
100	610	200	200	40	100	100	875	450	370	415	415	VSH100
200	750	300	300	50	100	150	1100	550	450	485	500	VSH200

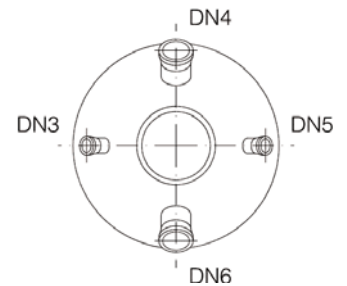
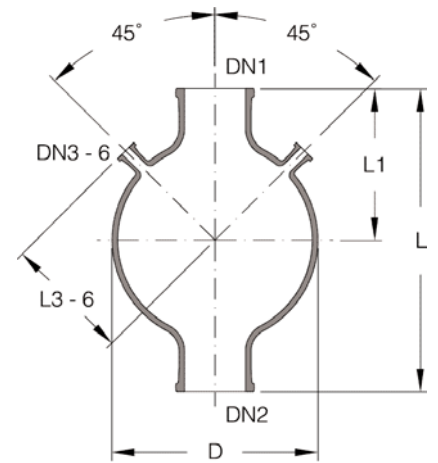

JACKETED SPHERICAL VESSELS

As an alternative to heating the contents of spherical vessels in heating mantles (please see page 4.31) or heating baths (please see pages 4.32 and 4.33) they can also be supplied up to a nominal capacity of 50 litre with a borosilicate glass 3.3 jacket. This is welded to the vessel at both ends.

 Due to their design, jacketed spherical vessels must be supported at the top branch flange using tubular support frames.

If jacketed spherical vessels require a valve seat in order to fit a »BAL40« or »BAMD25« bottom outlet valve (please see Section 3 »Valves & Filters«) please add »BAL« or »BAMD« to the catalogue reference. For example »DVSM..BAL« or »DVSM..BAMD«.

Nominal capacity (l)	Dimensions for DVS...BAL			Dimensions for DVS...BAMD		
	DN2	L	L8	DN2	L	L8
10	40	575	120	40	590	135
20	40	700	145	40	700	145
50	40	850	115	40	855	120

The permissible operating conditions for the jacket and inner component can be found in Section 1 »Technical Information«.

Water or heat transfer fluids, can be used for heat transfer purposes. Our engineers will be pleased to advise on this subject.

The branches on the jacket are the safety buttress end type. If they are aligned horizontally and if long or heavy hoses are connected to them, we recommend 90° hose connectors to reduce the bending moment on the branches.

Borosilicate glass 3.3 and metal hose connectors can be found in Section 2 »Pipeline Components« and hoses in Section 9 »Couplings«.

The end form, which depends on the nominal size, is shown in the diagram on page 4.2. Further information can be found in Section 1 »Technical Information«.

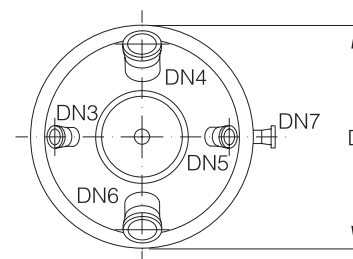
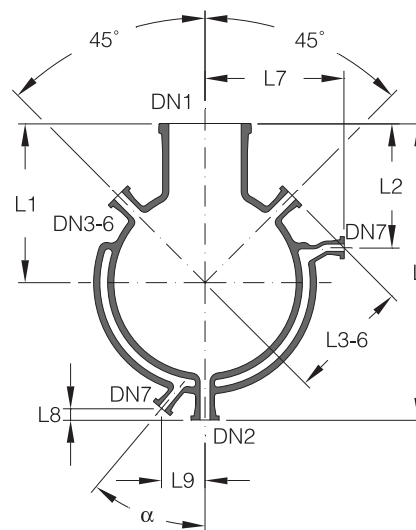

Nominal capacity (l)	D	DN1	DN2	DN3 DN5	DN4 DN6	DN7	L	L1	L2	L3 L5	L4 L6	L7	L8	L9	α (°)	Reference
10	350	100	40	-	-	25	550	250	210	-	-	255	95	125	40	DVSC10
20	415	100	40	-	-	25	635	325	300	-	-	275	80	120	40	DVSC20
50	610	200	40	-	-	25	800	400	325	-	-	370	65	140	40	DVSC50
10	350	100	40	40	80	25	550	250	210	205	225	255	95	125	40	DVSM10
20	415	100	40	40	80	25	635	325	300	240	260	275	80	120	40	DVSM20
50	610	200	40	40	80	25	800	400	325	380	400	370	65	140	40	DVSM50

CYLINDRICAL VESSELS

The version with full bore top neck can be used for a wide variety of purposes such as reaction vessels, separating vessels, receivers and feed vessels.

Cylindrical vessels with a reduced diameter top neck provide an economical alternative in some cases since they require a smaller vessel cover. These vessels are mainly used as receivers.

Vessel covers for use with these cylindrical vessels can be found on pages 4.18 to 4.20.

Graduated and jacketed (up to DN 300 nominal size) versions can be supplied as standard. Further information on these can be found on pages 4.11 to 4.15.



When cylindrical vessels require a valve seat in order to fit a »BAS40« or »BASD25« bottom outlet valve (please see Section 3 »Valves & Filters«) please add »BAS« to the catalogue reference. For example »VZ..BAS« or »VZ..BASD« (dimension L increases in accordance with the table below).

Reference	Nominal capacity (l)	DN1/DN2	L for VZ...BAS	L for VZ...BASD
VZ5/150...	5	40	510	545
VZ10/200	10	40	600	635
VZ20/300	20	40	550	610
VZ30/300	30	40	695	730
VZ50/300	50	40	945	980
VZN100/450	100	40	935	980
VZN150/450	150	40	1240	1275
VZN200/450	200	40	1545	1580
VZN400/600	400	40	1735	1770
VZN500/800	500	40	1240	1275
VZ750/1000	750	40	1300	1335
VZ20/150	20	40	700	730
VZ30/150	30	40	845	880
VZ50/150	50	40	1045	1080
VZ100/200	100	40	1145	1180
VZ150/200	150	40	1445	1480
VZ200/200	200	40	1670	1705
VZ300/200	300	40	1535	1570

Cylindrical vessels with a full bore top neck and nominal capacities of 5 to 10 litre can be suspended from the upper backing flange. All other vessels should be supported by the appropriate holder as described in Section 10 »Structures & Supports«.

All cylindrical vessels with reduced diameter top neck should be supported by a vessel holder (please see Section 10 »Structures & Supports«).

CYLINDRICAL VESSELS

Universal Cylindrical Vessels

Nominal capacity (l)	DN	DN 1	L	L1	Reference
5	150	25	460	400	VZ5/150
10	200	25	550	490	VZ10/200
20	300	25	500	440	VZ20/300
30	300	40	650	585	VZ30/300
50	300	40	900	835	VZ50/300
100	450	40	890	825	VZN100/450
150	450	40	1195	1130	VZN150/450
200	450	40	1500	1435	VZN200/450
400	600	50	1700	1625	VZN400/600
500	800	80	1250	1130	VZN500/800
750	1000	80	1300	1190	VZ750/1000

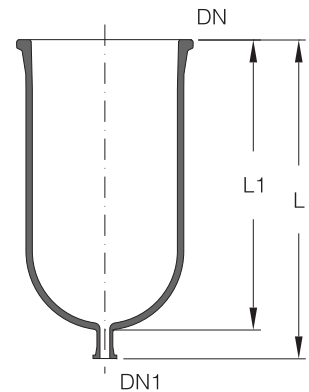

CYLINDRICAL VESSELS

Cylindrical Receivers

Nominal capacity (l)	DN	DN 1	DN2	L	L1	Reference
20	300	150	25	650	590	VZ20/150
30	300	150	40	800	735	VZ30/150
50	300	150	40	1000	935	VZ50/150
100	450	200	40	1100	1035	VZ100/200
150	450	200	40	1400	1335	VZ150/200
200	450	200	40	1625	1560	VZ200/200
300	600	200	50	1500	1425	VZ300/200

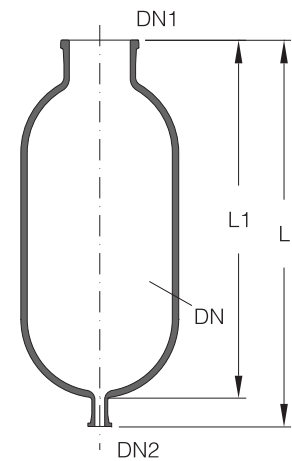

GRADUATED CYLINDRICAL VESSELS

The specification for the standard graduations for each size of vessel are given in the tables. Universal cylindrical vessels and cylindrical receivers can also be supplied with graduations to meet your particular requirements.



Cylindrical vessels calibrated in more precise increments, also including the volume of the outlet valve, can be supplied upon request.

The end form, which depends on the nominal size, is shown in the diagram on page 4.2. Further information can be found in Section 1 »Technical Informaton«.

GRADUATED CYLINDRICAL VESSELS

Universal Cylindrical Vessels

Nominal capacity (l)	DN	DN 1	L	L1	Graduations (l)	Reference
5	150	25	460	400	0,25	VZG5/150
10	200	25	550	490	0,5	VZG10/200
20	300	25	500	440	2	VZG20/300
30	300	40	650	585	2	VZG30/300
50	300	40	900	835	2	VZG50/300
100	450	40	890	825	5	VZGN100/450
150	450	40	1195	1130	5	VZGN150/450
200	450	40	1500	1435	5	VZGN200/450
400	600	50	1700	1625	5	VZGN400/600
500	800	80	1250	1130	10	VZGN500/800
750	1000	80	1300	1190	20	VZG750/1000

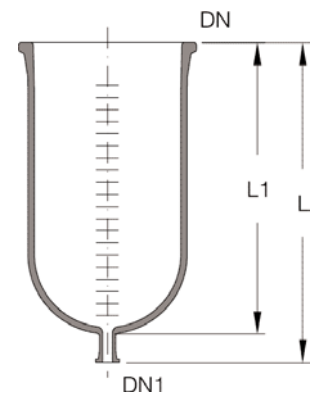

GRADUATED CYLINDRICAL VESSELS

Cylindrical Receivers

Nominal capacity (l)	DN	DN1	DN2	L	L1	Graduations (l)	Reference
20	300	150	25	650	590	2	VZG20/150
30	300	150	40	800	735	2	VZG30/150
50	300	150	40	1000	935	2	VZG50/150
100	450	200	40	1100	1035	5	VZG100/200
150	450	200	40	1400	1335	5	VZG150/200
200	450	200	40	1625	1560	5	VZG200/200
300	600	200	50	1500	1425	5	VZG300/200

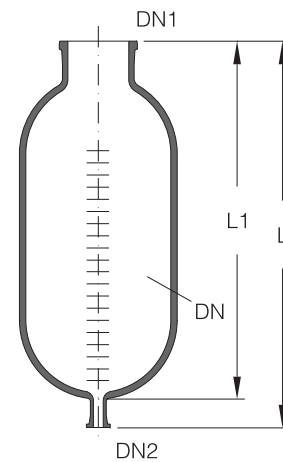

JACKETED CYLINDRICAL VESSELS

Up to a nominal capacity of 100 litres, cylindrical vessels with full bore or reduced diameter top branch can also be supplied with a borosilicate glass 3.3 jacket. In the case of the smaller sizes (up to 30 litres capacity) this is welded to the vessel at both ends. In the larger sizes it is only welded to the vessel at its upper end and a flexible seal is used on the bottom outlet branch.



Due to their design, jacketed cylindrical vessels should be supported on the top neck flange using tubular support frames (see Section 10 »Structures & Supports«). Further information can be obtained from our sales department.

If jacketed cylindrical vessels require a valve seat in order to fit a »BAL40« bottom outlet valve (please see Section 3 »Valves & Filters«) please add »BAL« to the catalogue reference. For example »DVZ..BAL«. (dimensions will vary as indicated in the table below).

For vessels up to 30 liters volume with welded glass jackets, »DVZ...BAL« or "DVZ...BAMD" are used.

For vessels larger than 30 liters volume, "DVZ...BAS" or "DVZ...BALD" are used.

Vessels with drainage nozzles (for valve type BAL)

Reference	DN1	DN2	L	L3	L4	α (°)
DVZ5/150BAL	40	-	640	150	115	40
DVZ10/200BAL	40	-	680	145	120	40
DVZ20/150BAL	-	40	815	135	120	40
DVZ20/300BAL	40	-	660	135	120	40
DVZ30/150BAL	-	40	960	135	120	40
DVZ30/300BAL	40	-	805	135	120	40
DVZ50/150BAL	-	40	1240	150	145	40
DVZ50/300BAL	40	-	1090	150	145	40
DVZ100/450BAL	40	-	1030	140	145	40

Vessels with integrated drainage nozzles (for valve types BAMD, BALD)

Reference	DN1	DN2	L	L3	L4	α (°)
DVZ5/150BAMD	40	-	645	155	115	40
DVZ10/200BAMD	40	-	685	150	120	40
DVZ20/150BAMD	-	40	820	140	120	40
DVZ20/300BAMD	40	-	665	140	120	40
DVZ30/150BAMDDV	-	40	965	140	120	40
Z30/300BAMD	40	-	810	140	120	40
DVZ50/150BALD	-	40	1295	205	145	40
DVZ50/300BALD	40	-	1145	205	145	40
DVZ100/450BALD	40	-	1085	198	150	40

The permissible operating conditions for the jacket and inner component can be found in Section 1 »Technical Information«.

Water or heat transfer fluids can be used for heat transfer purposes.

JACKETED CYLINDRICAL VESSELS

Universal Cylindrical Vessels

Nominal capacity (l)	DN	DN1	DN2	D	L	L1	L2	L3	L4	α (°)	Type	Reference
5	150	25	25	215	535	135	180	35	100	40	A	DVZ5/150
10	200	25	25	270	580	100	205	30	100	40	A	DVZ10/200
20	300	25	25	390	555	125	255	28	110	40	A	DVZ20/300
30	300	40	25	390	705	125	255	33	110	40	A	DVZ30/300
50	300	40	25	390	1050	125	255	100	130	40	B	DVZ50/300
100	450	40	25	520	990	150	330	100	140	40	B	DVZ100/450

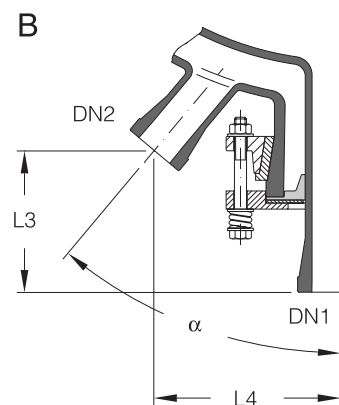
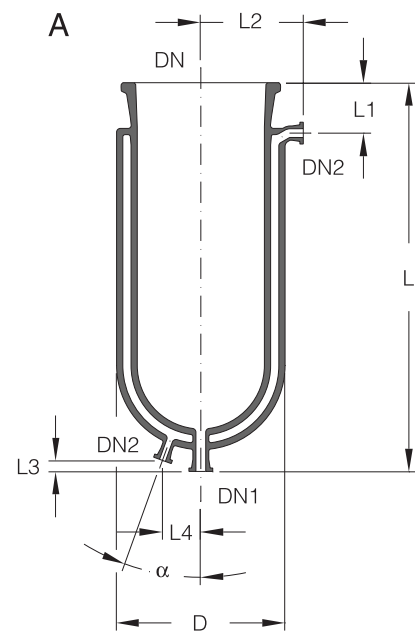

JACKETED CYLINDRICAL VESSELS

Cylindrical Receivers

Nominal capacity (l)	D	DN	DN1	DN2	DN3	L	L1	L2	L3	L4	α (°)	Type	Reference
20	390	300	150	25	25	710	280	255	28	110	40	A	DVZ20/150
30	390	300	150	40	25	860	280	255	33	110	40	A	DVZ30/150
50	390	300	150	40	25	1200	280	255	100	130	40	B	DVZ50/150

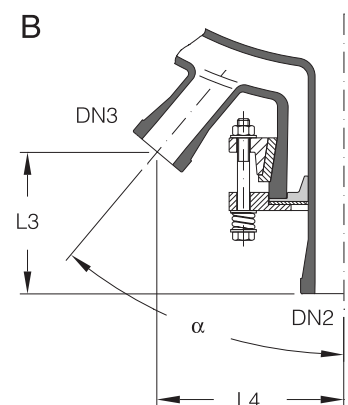
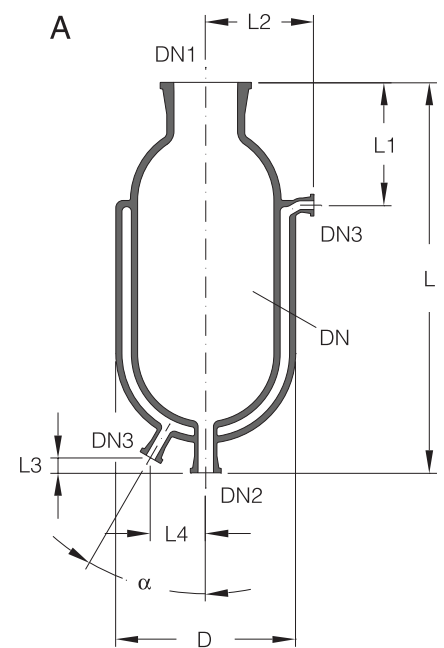

MOBILE VESSELS

Mobile vessels comprise of a mobile support structure with five steerable, antistatic castors (two fitted with brakes) with a cylindrical or spherical vessel fixed within it.

Mobile vessels can also be supplied with a centrifugal pump with single mechanical seal and borosilicate glass 3.3 body. Technical details can be found below.

Motor (kW)	0.25
Motor speed (min⁻¹)	2900
Voltage (V), 50 Hz	230/400
Protection Type	EEx e II T3

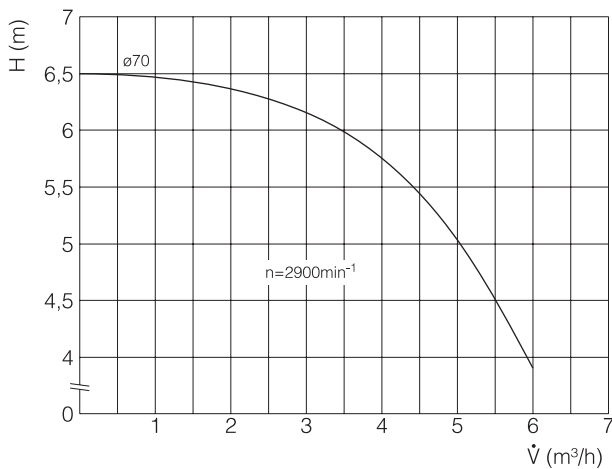

Pump head versus delivery (water, 20 °C)

These vessels are ideal for pilot plant and production use to transport and store products.

Cylindrical mobile vessels can be supplied from 30 to 200 litre and spherical vessels from 50 to 200 litre. If required, they can also be graduated (please see page 4.11 as an example). The version without pump is fitted with a DN 40 drain valve and the version with pump incorporates a DN 25 drain valve plus a DN 25 and DN 15 angle valve on either side of the pump.

MOBILE VESSELS

Mobile Cylindrical Vessels

Nominal capacity (l)	DN	DN 1	D	H	Reference without pump	Reference with pump
30	300	50	821	1545	VGFN30	VGPN30
50	300	50	821	1795	VGFN50	VGPN50
100	450	50	962	1945	VGFN100	VGPN100
150	450	50	962	2245	VGFN150	VGPN150
200	450	50	962	2545	VGFN200	VGPN200

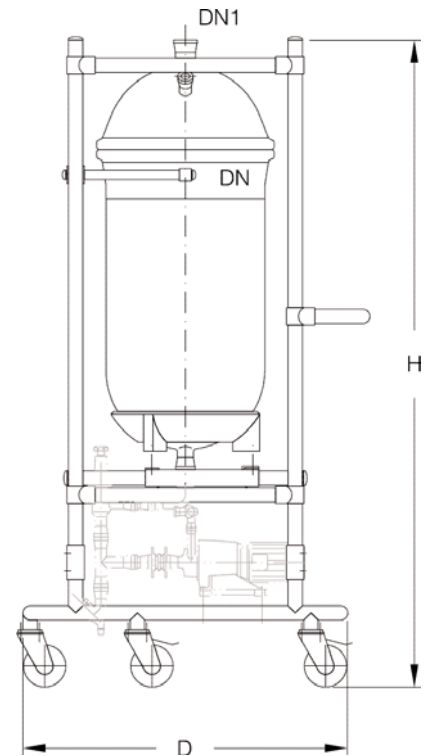

MOBILE VESSELS

Mobile Spherical Vessels

Nominal capacity (l)	DN1	D	H	Reference without pump	Reference with pump
50	200	962	1370	VFN50	VFPN50
100	200	962	1470	VFN100	VFPN100
200	300	1245	1700	VFN200	VFPN200

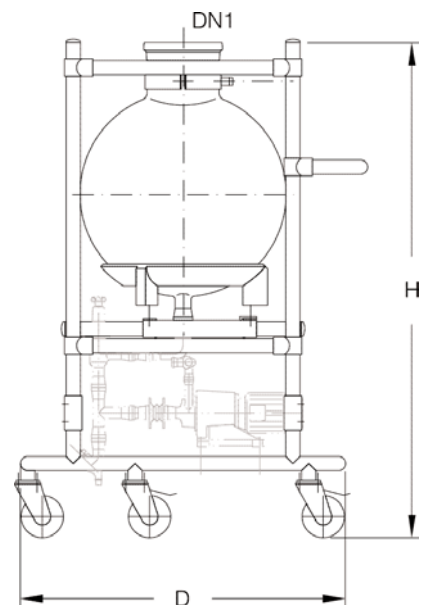

VESSEL COVERS

These components provide the optimum, vacuum-tight closure for vessels. They facilitate observation of the process even after fitting or adding dip pipes (please see pages 4.21 and 4.22), stirrers (please see pages 4.35 to 4.40), or measuring instruments (please see section 8 »Measurement & Control«) etc..

Vessel covers with alternative branch sizes and configurations can also be supplied to meet your special requirements.



If the unit is to be operated under vacuum or at atmospheric pressure, charge branches can be fitted with a quick release coupling (please see Section 9 »Couplings«).

The end form, which depends on the nominal size, is shown in the diagram on page 4.2. Further information can be found in Section 1 »Technical Information«.

VESSEL COVERS

Covers for Receivers and Spherical Vessels

These covers are intended for use with spherical and cylindrical vessels used as receivers. They can, however, also be used with stirrer assemblies.

DN	DN1	DN2	d	L	L1	L2	Type	Reference
100	50	2 x 15	-	175	79	106	A	VZC100/50
150	50	2 x 25	-	200	113	133	A	VZC150/50
200	50	2 x 25	-	175	126	126	B	VZC200/50
200	-	3 x 40	150	-	175	-	C	VZA200
300	50	2 x 25	-	225	161	161	B	VZC300/50
300	80	3 x 40	245	250	225	-	C	VZA300/80
450	50	2 x 40	-	325	221	221	B	VZC450/50
600	50	2 x 40	-	375	264	264	B	VZC600/50
800	80	2 x 80	-	550	389	389	B	VZC800/80
1000	80	2 x 80	-	650	488	413	B	VZC1000/80

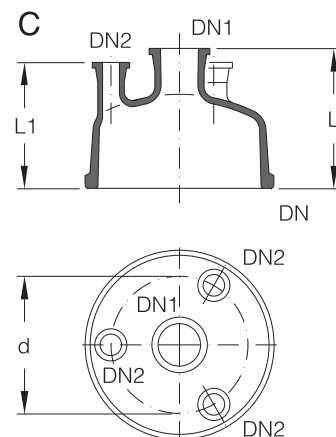
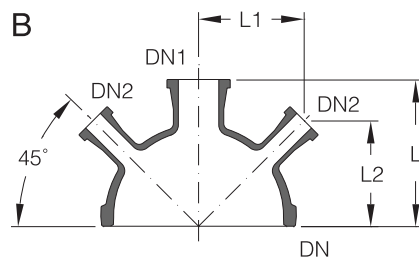
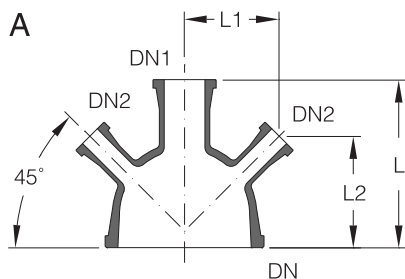

VESSEL COVERS

Covers with Central Stirrer Branch

These vessel covers have a centre branch for use in conjunction with a stirrer. We recommend the incorporation of a baffle to promote turbulence when used with propeller and turbine stirrers.

DN	DN1	DN2	DN3	DN4	d	L	L1	L2	L3	L4	Type	Reference
300	50	80	3 x 40	-	245	250	188	188	225	-	A	VZMC300/50
	80	80	2 x 40	-	245	250	188	188	225	-	B	VZMC300/80
450	50	150	2 x 40	50	350	325	262	259	285	285	C	VZMC450/50
	80	150	2 x 40	50	350	325	262	259	285	285	C	VZMC450/80
	100	150	2 x 40	50	350	350	262	259	285	285	C	VZMC450/100
600	50	150	2 x 40	50	400	375	291	290	335	335	C	VZMC600/50
	80	150	2 x 40	50	400	375	291	290	335	335	C	VZMC600/80
	100	150	2 x 40	50	400	400	291	290	335	335	C	VZMC600/100
800	80	150	3 x 80	-	450	550	386	386	525	-	C	VZMC800/80
	100	150	3 x 80	-	450	550	386	386	525	-	C	VZMC800/100
	150	150	3 x 80	-	450	575	386	386	525	-	C	VZMC800/150
1000	80	150	3 x 80	-	500	650	487	412	600	-	C	VZMC1000/80
	100	150	3 x 80	-	500	650	487	412	600	-	C	VZMC1000/100
	150	150	3 x 80	-	500	650	487	412	600	-	C	VZMC1000/150

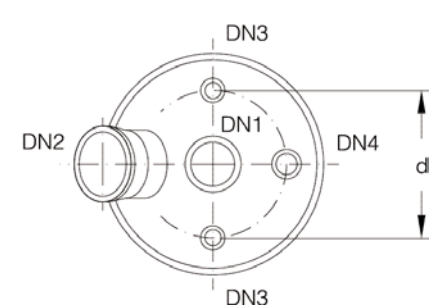
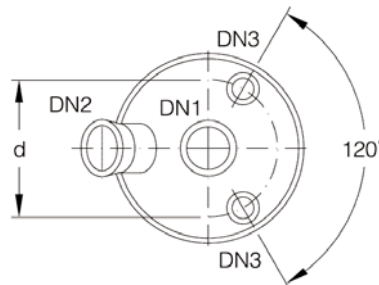
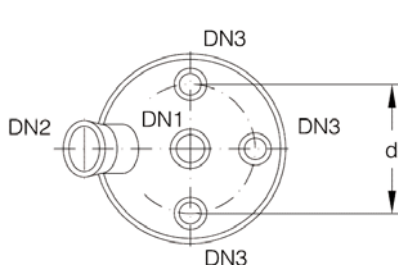
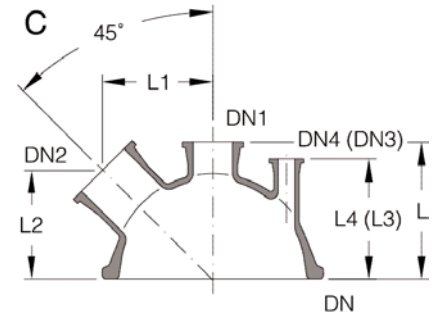
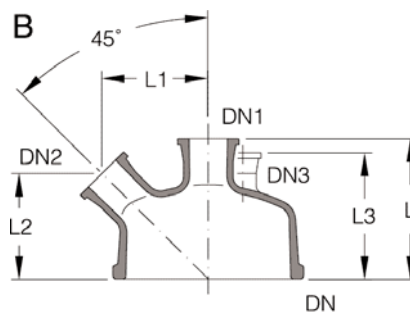
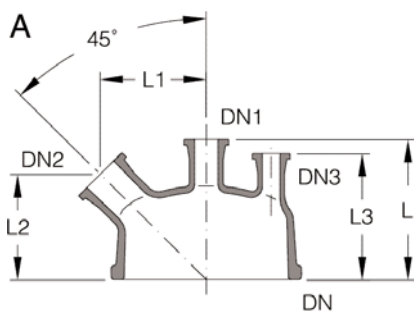

VESSEL COVERS

Covers with Eccentric Stirrer Branch

As the branch provided on these covers for fitting a stirrer is located off-centre, the possibility of a vortex being set up is avoided to a large extent even when propeller and turbine stirrers are used.

DN	DN1	DN2	DN3	d	L	L1	L2	L3	L4	Reference
200	50	50	-	-	200	40	139	139	-	VZME200/50
300	50	80	40	245	250	60	188	188	225	VZME300/50

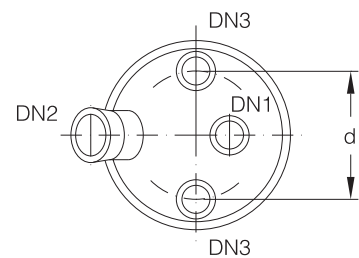
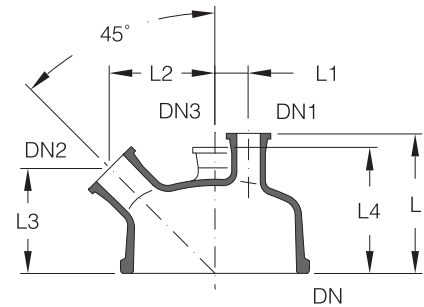

VESSEL COVERS

Covers for Reaction Vessels

These covers complement the range described above. They have a centre branch for use in conjunction with a stirrer, two extra large branches for overhead gear and charge port plus various other connections.

DN	DN1	DN2	DN3	DN4	L	L1	L2	L3	L4	Reference
450	80	100	80	50	325	175	247	232	285	VZR450/80
600	100	100	80	50	400	200	288	291	335	VZR600/100

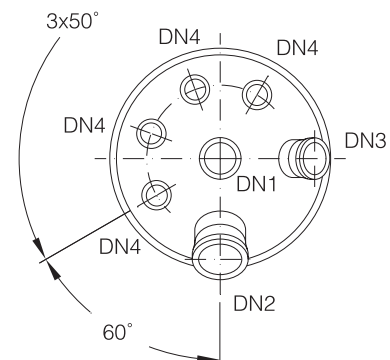
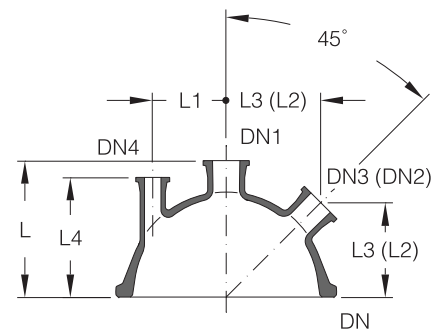

DIP PIPES

The design of the dip pipe depends on the arrangement of the branches on the vessel cover used with spherical or cylindrical vessels.



Type »DP../100« can be used as a standard dip pipe irrespective of the branch arrangement.

Dip pipes with other lengths can be supplied on request.

DIP PIPES

Straight Dip Pipes

These can only be used in conjunction with vertically aligned branches on vessel covers.

DN	DN1	d	L	L1	Type	Reference
25	25	18	100	100	A	DP25/100
40	25	28	100	100	B	DP40/100
40	25	28	100	300	B	DP40/300
40	25	28	100	500	B	DP40/500
40	25	28	100	650	B	DP40/650
40	25	28	100	850	B	DP40/850
50	25	28	100	100	B	DP50/100
50	25	28	100	300	B	DP50/300
50	25	28	100	525	B	DP50/525
50	25	28	100	650	B	DP50/650
50	25	28	100	875	B	DP50/875

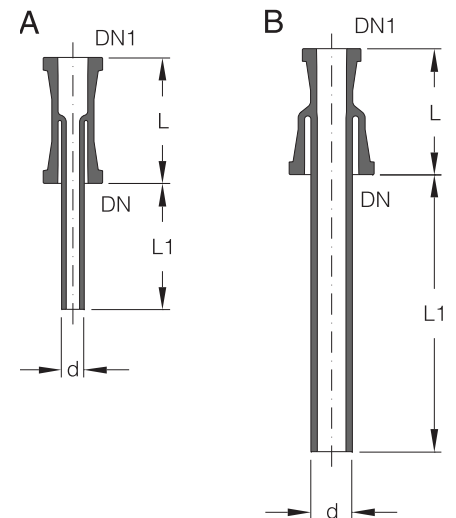

DIP PIPES

Angled Dip Pipes

This version should be selected for use with branches aligned at 45° for type »VZC..« vessel covers on spherical and cylindrical vessels which are generally used as feed vessels or receivers.

DN	DN1	d	L	L1	L2	Reference
25	15	13	100	95	115	DP45/25/115
25	15	13	100	115	150	DP45/25/150
40	25	28	100	115	115	DP45/40/115
40	25	28	100	135	165	DP45/40/165
40	25	28	100	150	260	DP45/40/260
40	25	28	100	150	345	DP45/40/345
50	25	33	100	150	150	DP45/50/150
50	25	33	100	150	245	DP45/50/245
50	25	33	100	150	335	DP45/50/335
50	25	33	100	150	435	DP45/50/435
80	50	59	125	200	265	DP45/80/265
80	50	59	125	200	365	DP45/80/365
80	50	59	125	275	525	DP45/80/525

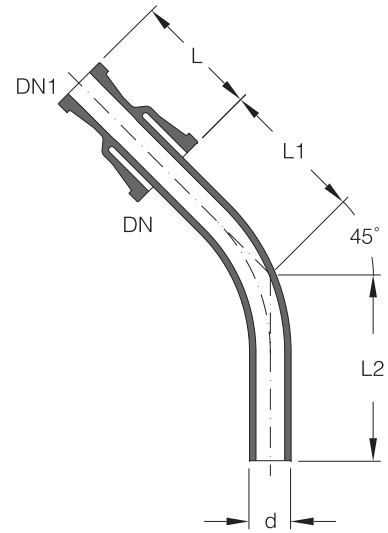

GLASS-LINED REACTION VESSELS

In addition to jacketed glass vessels (see pages 4.8 and 4.13 to 4.15), these glasslined vessels are also suitable for carrying out reactions with simultaneous heating or cooling. Additionally, due to their unique design, they form the basis for our standard series of GMP reaction units.

They are supplied as standard with a main body flange of the same diameter as the reactor body, and are thus suitable for the use of both anchor and impeller-type agitators. The jacket extends all the way up to the main flange, and is equipped with turbulence enhancing nozzles to maximise heat transfer performance. Either steam or thermal oil can therefore be used as the heating medium.

The vessels are designed for use with glass covers (see page 4.10), to permit constant visual monitoring of the entire reaction process. The glass bottom outlet valve seats onto the integral block flange at the base of the reactor, with minimum dead volume.

The glass foam insulation (in the VERI.. version) is sheathed in stainless steel, which is welded top and bottom directly onto the reactor, to totally seal the insulation. The jacket sheath can also be supplied in a polished version on request. Non-insulated reaction vessels are fitted with angle plates to which the support brackets are attached. For insulated vessels, the support brackets are welded directly onto the insulation sheathing, thus providing a thermal barrier between the reactor and its supports.

Together with the agitator drives and agitators described on pages 4.35 to 4.45, these reaction vessels form the basis of our Universal Reaction System. Standard fractionation columns, or overheads designed to meet your specific requirements, can also be supplied.

Upon request, we also offer Optimix type reactor vessels made of stainless steel and of borosilicate glass up to 25 liters. On request, we also supply these reaction vessels in other materials such as stainless steel or hastelloy. If required, the vessel can also be fabricated to a very high standard of internal finish, with ground welded seams and/or electrolytically polished surfaces.



The internal pressure and temperature ratings are -1 to 1 bar g, and -60 to 200 °C. The maximum working pressure of a complete reaction unit is dictated by the pressure rating of the glass components selected for the overhead equipment. The vessels are capable of withstanding full vacuum.

The maximum operating pressure in the jacket is 10 bar g, with a temperature range of -60 to 200 °C. Higher pressures are available upon request.

The bottom outlet valve and the attachment bolts for the glass cover are included in the scope of supply.

GLASS-LINED REACTION VESSELS

Reaction Vessels

Nominal capacity (l)	DN	DN1	DN2	D2	D3	D4	n x d	d1	K	K1	Type	Reference
25	450	25	40	380	615	-	16 x 10	18	585	625	A	VER25
25	450	25	40	380	615	664	16 x M8	18	585	740	B	VERI25
40	450	25	40	380	615	-	16 x 10	18	585	625	A	VER40
40	450	25	40	380	615	664	16 x M8	18	585	740	B	VERI40
63	450	25	40	430	615	-	16 x 10	18	585	680	A	VER63
63	450	25	40	430	615	762	16 x M8	18	585	850	B	VERI63
100	600	25	40	580	755	-	20 x M12	18	710	880	A	VER100
100	600	25	40	580	755	910	20 x M12	18	710	1000	B	VERI100

Nominal capacity (l)	L	L1	L2	L3	L4	L5	H	H1	E1	Type	Reference
25	125	355	73	92	280	340	718	-	320	A	VER25
25	125	355	73	92	280	340	718	210	320	B	VERI25
40	125	485	73	92	280	340	848	-	400	A	VER40
40	125	485	73	92	280	340	848	260	400	B	VERI40
63	125	575	23	92	300	360	888	-	350	A	VER63
63	125	575	23	92	300	360	888	380	350	B	VERI63
100	125	525	33	92	350	460	848	-	350	A	VER100
100	125	525	33	92	350	460	848	340	350	B	VERI100

Technical Data

Reference	Nominal capacity (l)	Max. Volume (l)	Heat transfer area		stirred Volume (l)
			Nominal (m ²)	max. (m ²)	
VER25, VERI25	25	43	0,37	0,52	5,7
VER40, VERI40	40	60	0,53	0,68	5,7
VER63, VERI63	63	80	0,75	0,87	8,3
VER100, VERI100	100	128	0,90	1,04	12,6

A

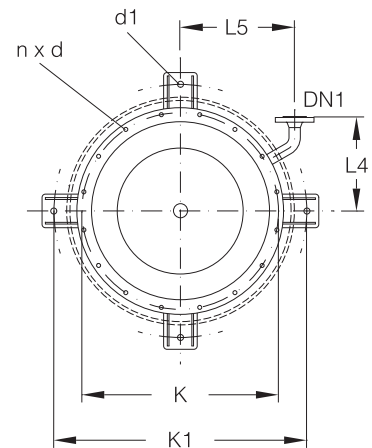
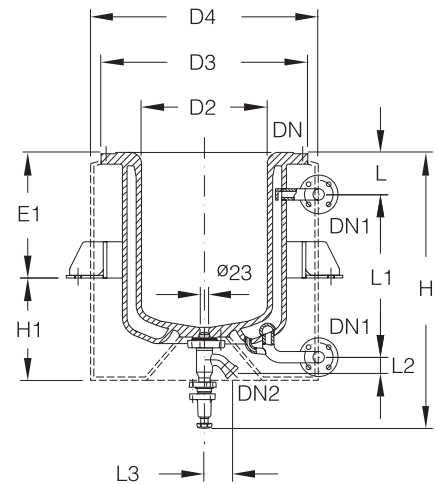

B

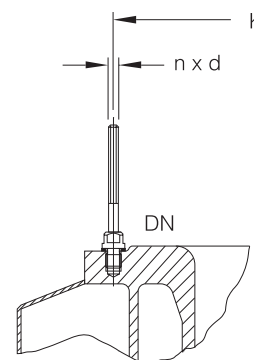

HORIZONTAL SEPARATORS

The continuous separation of immiscible liquids with different densities requires low flow rates and the largest possible phase-interface between the light and heavy phase. Horizontal separators satisfy these requirements perfectly.

The separation layer is controlled by means of an adjustable overflow valve that can be installed either outside the separator (please see »OF.«, Section 3 »Valves & Filters«) or sealed into it (»AOF.«). The internals of the two types of overflow valve are identical for the same nominal size.

The table below indicates typical figures for maximum possible throughputs in these separators. These are based on water at 20° C and are measured without any head in the input and can only be achieved up to the minimum density difference stated and for built-in overflow valves. We would be pleased to provide an exact layout for you. Non-standard and intermediate sizes (up to DN 1000 and of different lengths), especially for smaller density differences, can also be supplied upon request.

DN	Maximum flow rate \dot{V} at low to medium Interfacial tension Σ heavy (H.P.) and light phase (L.P.) (l/h)	Maximum flow rate heavy phase (H.P.) for overflow valve (l/h)	Minimum difference $\Delta\rho$ at flow rat \dot{V} (kg/m ³)
100	200	400	100
150	400	600	100
200	800	900	100
300	1700	1600	100
450	4000	3200	100
600	7000	5000	100
800	12000	7000	100

The borosilicate glass 3.3 coalescer illustrated on page 4.28 is a special feature and it conforms to GMP requirements. It is available in nominal sizes up to DN 300 and can be incorporated into all horizontal separators and mixer-settlers. It is used to speed up coalescence which would otherwise be very slow with fine dispersion (please request special leaflet).



The end form, which depends on the nominal size, is shown in the diagram on page 4.2. Further information can be found in Section 1 »Technical Information«.

HORIZONTAL SEPARATORS

Horizontal Separators without Overflow Valve

Two supporting brackets for fixing the horizontal separator in the structure are included within the scope of supply. (Please see dimensions in the table below and section 10 »Structures & Supports«)

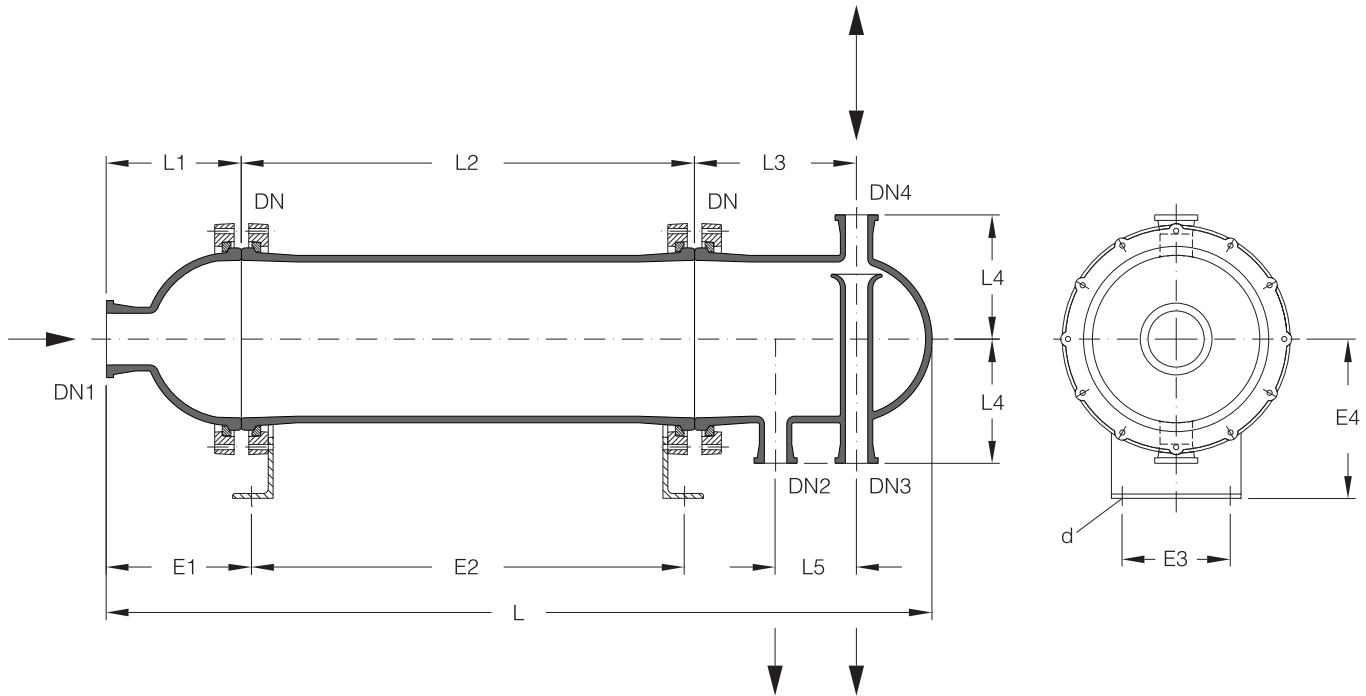

DN	DN1	DN2 (H.P.) DN3 (L.P.) DN4 (vent)	L	L1	L2	L3	L4	L5	Reference
100	25	15	950	150	500	200	120	100	A100
150	40	25	1000	200	500	200	140	100	A150
200	80	40	1580	200	1000	245	175	120	A200
300	100	50	2190	250	1500	300	230	150	A300
450	150	80	2950	350	2000	355	330	175	AN450

Dimensions

DN	E1	E2	E3	E4	d
100	174	452	110	165	13
150	216	468	200	208	14
200	218	964	200	243	14
300	269	1463	200	295	14
450	650	1400	300	280	18

HORIZONTAL SEPARATORS

Horizontal Separators with Built-In Overflow Valve

Two supporting brackets for fixing the horizontal separator in the structure are included within the scope of supply. (Please see dimensions in the table below and section 10 »Structures & Supports«).

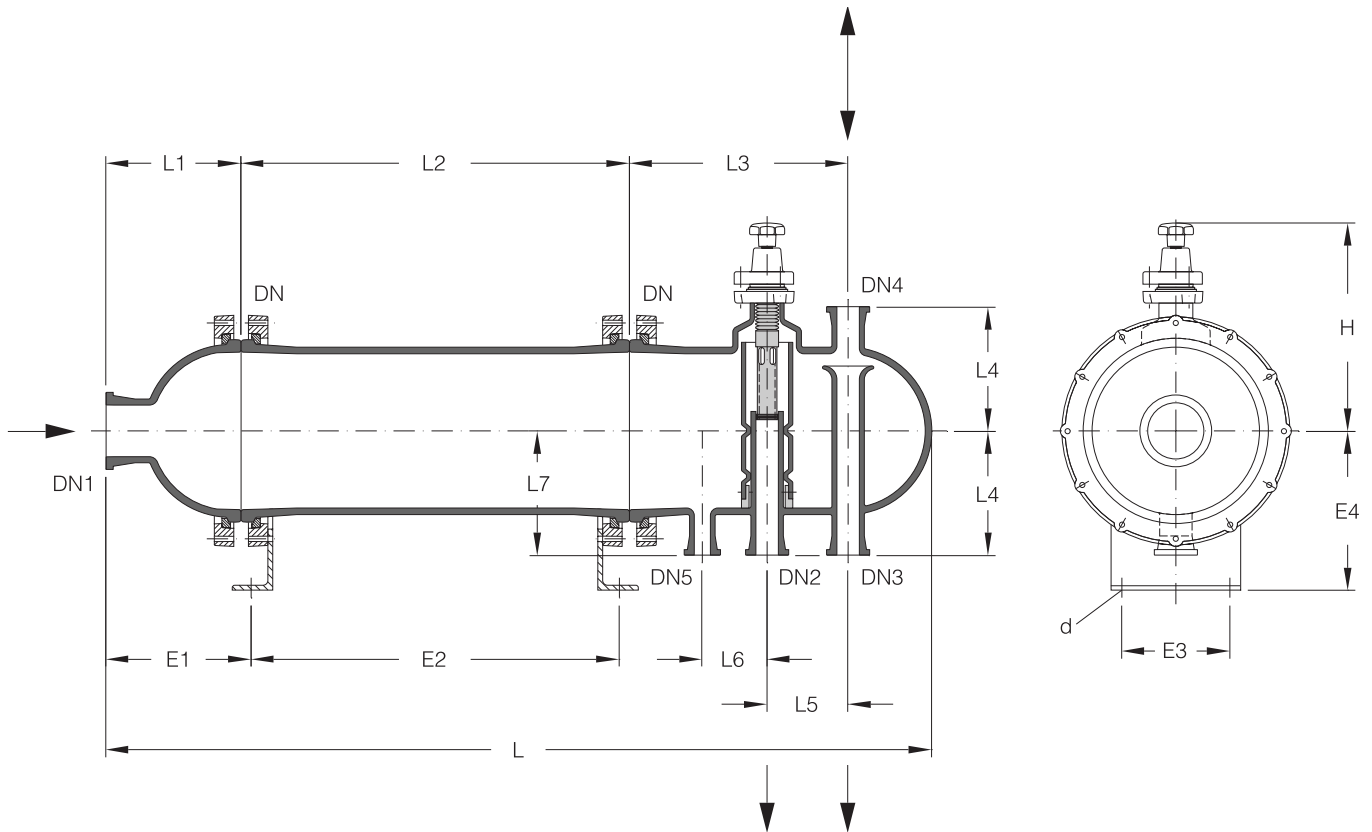

DN	DN1	DN2 (H.P.) DN3 (L.P.) DN4 (vent)	DN5	L	L1	L2	L3	L4	L5	L6	L7	H	Reference
100	25	15	15	950	150	500	220	110	70	70	110	252	AOF100/15
150	40	25	25	1100	200	500	300	140	100	100	140	274	AOF150/25
200	80	40	25	1680	200	1000	345	175	120	100	175	349	AOF200/40
300	100	50	40	2310	250	1500	405	230	150	120	230	386	AOF300/50
450	150	80	40	3075	350	2000	475	330	175	150	305	500	AOF450/80
600	150	100	40	2750	425	1500	575	420	225	175	380	640	AOF600/100
800	150	100	40	3140	575	1500	600	535	225	175	495	775	AOF800/100

Dimensions

DN	E1	E2	E3	E4	d
100	174	452	110	165	13
150	216	468	200	208	14
200	218	964	200	243	14
300	269	1463	200	295	14
450	650	1400	300	280	14
600	725	900	400	362	14
800	925	800	630	475	14

HORIZONTAL SEPARATORS

Coalescers

Special features of these items are resistance to fouling, their ability to break down foam and their high efficiency with a limiting drop size of 20 μm and a maximum flow volume, based on the empty pipe, of 25 $\text{m}^3/\text{m}^2 \text{ h}$ (please see pages 4.26 and 4.27).



If the number of individual elements required differs from the figure shown in the table below, please specify the number required when ordering.

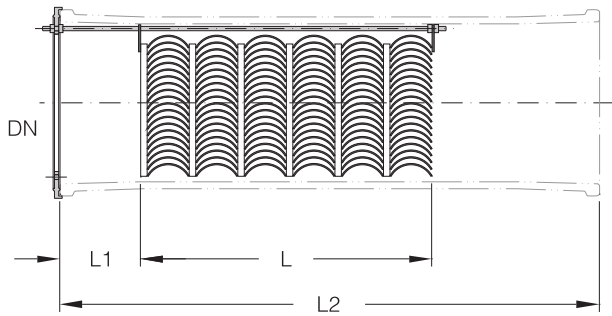

DN	L	L1	L2	Number of elements	Capacity \dot{V} (l/h)	Reference
100	360	100	500	4	200	COSA100
150	360	100	500	4	400	COSA150
200	540	150	1000	6	800	COSA200
300	540	150	1000	6	1700	COSA300

MIXER-SETTLERS

Mixer-settlers are used for extraction processes wherever there are great demands in flexibility on the operation of the plant. Frequently changing products, alterations to the number of stages required or wide variations in throughput can be decisive factors in this decision process. A precondition for their use is, however, that only a restricted number of theoretical stages is required.

Scaling-up presents no problem since back-mixing effects can be excluded completely by the clear separation of the light and heavy phases in each stage. When properly sized, each practical stage also corresponds approximately to a theoretical stage.

Each mixer-settler stage consists of a mixing chamber with a self-priming, variable speed stirrer as shown in the diagram below and a horizontal separator without a reducer on the inlet end (please see »AOF..«, page 4.27), i.e. the two phases are mixed in each stage then allowed to settle and separate from each other. The assemblies indicated, i.e. mixer and settler zone, are physically separated by a weir fitted within the flange coupling.

By connecting several mixer-settler stages in series and arranging for the phases to flow countercurrent to each other, the plant can be adapted to handle the particular separation problem in hand.

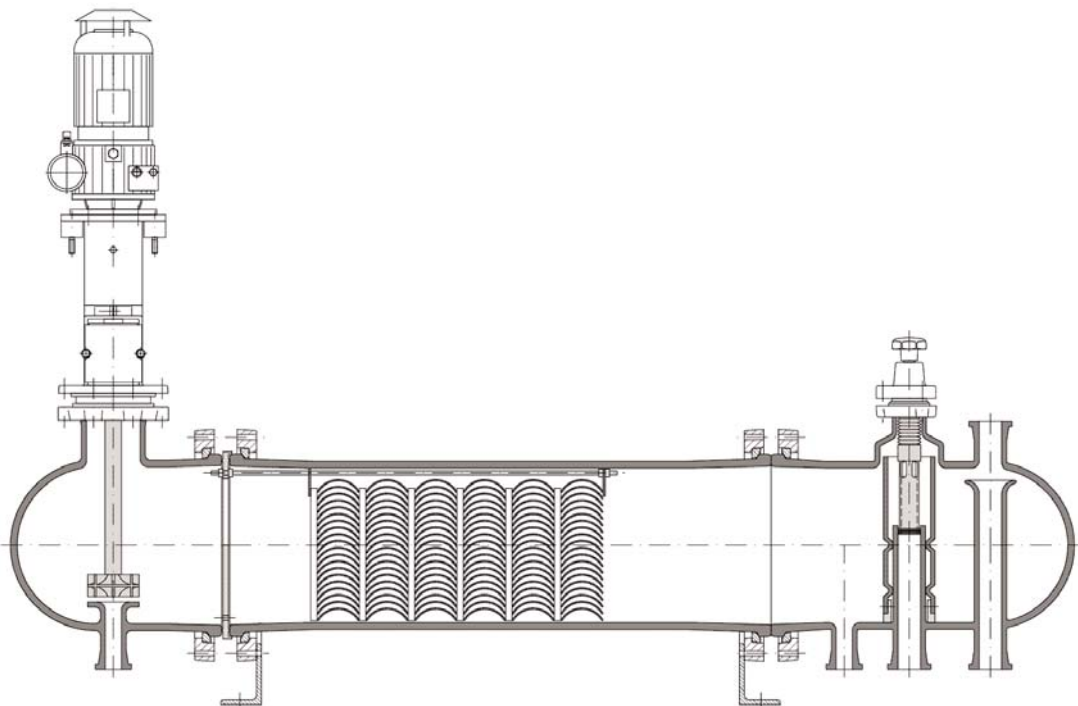

CYCLONES

The cyclones described here are designed for the separation not only of droplets from gases and vapours but also of particulate solids from gases. The overall degree of separation can be as high as 99%, but this figure is governed to a very large extent by the following parameters:

- Liquid loading of the gas or vapour or the solids loading of the gas
- Droplet or particle size range
- Droplet or particle size distribution

For the standard air/water system at ambient temperature and with a gas velocity of 15 m/s in the dip tube, limiting droplet diameters are approx. 2.5 μm for the DN 100 and DN 150 nominal sizes and approx. 3.5 μm for nominal sizes DN 200 and DN 300. The pressure drop in these cases is in the region of 25 to 30 mbar.

We would be pleased to provide an exact design for the cyclone you require.

DN	DN1	DN2	DN3	L	L1	L2	L3	L4	L5	Reference
100	40	25	80	714	560	180	284	125	35	CY100
150	50	25	100	839	655	235	349	150	55	CY150
200	80	25	150	1119	915	320	429	200	75	CY200
300	100	25	150	1425	1225	405	485	275	100	CY300

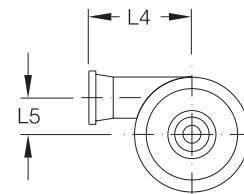
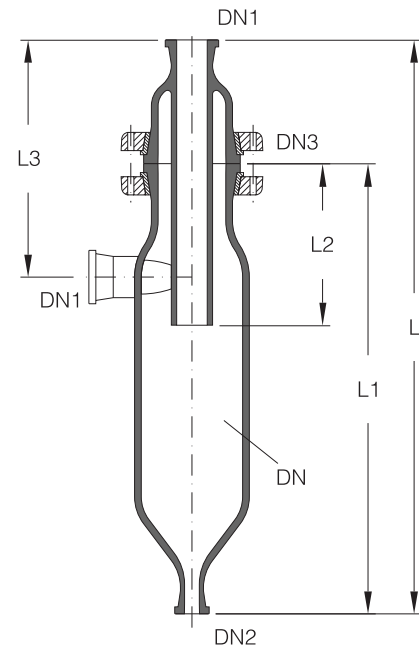

HEATING MANTLES FOR SPHERICAL VESSELS

As an alternative to heating baths (please see pages 4.32 and 4.33) electric heating mantles can also be supplied for spherical vessels. Their heating power varies according to the nominal capacity of the vessel involved.

These heating mantles are subdivided into several heating zones each of which is equipped with a temperature probe so that the surface temperature of the vessel can be monitored. These work in conjunction with the control unit included in the supply to prevent local hot spots occurring. The control unit also includes energy regulators which can be used to control the heat input separately for each heating zone depending on the liquid level.

For the heating mantle type HHW (version A), product temperature control is possible via an additional resistance thermometer (see Chapter 8 »Measurement/Control Devices«). If no product temperature control is needed, or if such is performed by use of an existing contact thermometer, the heating mantle may also be delivered with a simple control device (type HHK, version B).

The number of heating zones and supply voltage of the heating mantles are indicated in the table below.

Nominal capacity of spherical vessel (l)	power (kW)	Voltage(V), 50 Hz	Number of heating zones
10	1,6	230	3
20	2,4	230	3
50	4,5	230/400, 3ph	3
100	6,0	230/400, 3ph	4
200	9,0	230/400, 3ph	5

Heating mantles are fixed in the support structure using »KK50-...« or »KKO50-...« structure fittings or »RRM...« type support mount (see Section 10 »Structures & Supports«). The weight of the spherical vessels and other components used in conjunction with them must be supported on separate fixed points.

Heating mantles can also be supplied for cylindrical vessels on request.

 If the heating mantle is to be used for a spherical vessel without a bottom outlet or with a non-standard bottom outlet, the catalogue reference becomes »HH(W/K)..., but for spherical vessel without bottom outlet« or »HH(W/K)..., but for DN .. bottom outlet« respectively. The maximum nominal size for the outlet is DN100.

In view of the heat involved, a metal coupling must be used on the vessel's bottom outlet (please see Section 9 »Couplings«).

Nominal capacity of spherical vessel (l)	DN	D	D1	d2	d3	d4	L	H	Reference Typ A	Reference Typ B
10	40	280	370	313	120	4 x M12	10	185	HHW10	HHK10
20	40	350	440	388	120	4 x M12	15	230	HHW20	HHK20
50	40	490	580	555	120	4 x M12	20	300	HHW50	HHK50
100	40	610	700	676	120	4 x M12	20	380	HHW100	HHK100
200	50	750	840	821	140	4 x M12	20	445	HHW200	HHK200

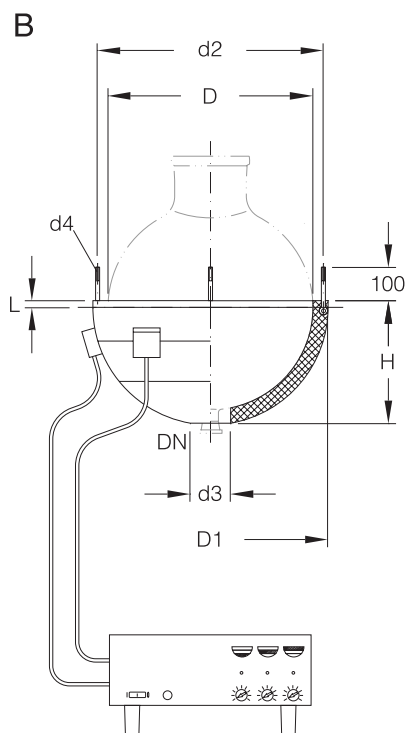
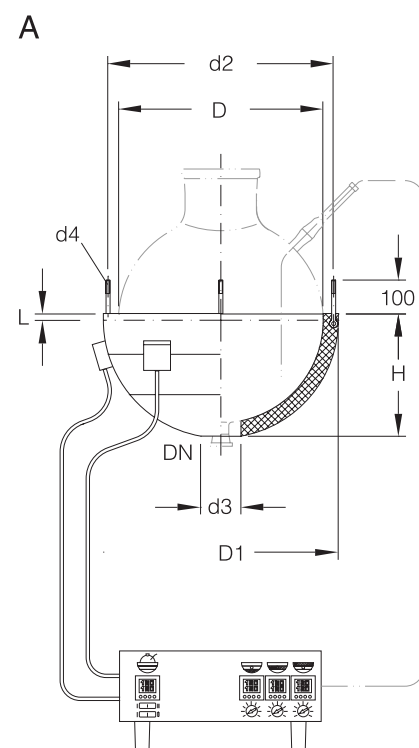

HEATING BATHS FOR SPHERICAL VESSELS

Heating baths can be used to advantage in applications where the materials being handled would tend to block or stick to the coils of immersion heat exchangers or where the use of heating mantles is not recommended. Options are available for heating either electrically or with steam.

The spherical vessel sits on a support ring and a restraint prevents it from floating up. A stuffing box seals the bottom outlet to prevent leakage from the bath. The design also avoids imposing any stresses on the spherical vessel.

The baths are made of steel. The external surface is primed and painted.

The heat transfer fluid in the bath can be, for example, water of boiler feed water quality or a synthetic oil. The bath temperature must always be a sufficient amount below the boiling temperature of the fluid. To ensure that this condition is met, the heating baths can be fitted with suitable temperature control equipment if required.

Complete stainless steel heating baths and heating baths for cylindrical vessels can be supplied to special order.

 Where it is necessary to ensure that the liquid in the bottom outlet is heated it is recommended to use spherical vessels with »BAL40« bottom outlet valve (please see Section 3 »Valves & Filters«).

HEATING BATHS FOR SPHERICAL VESSELS

Heating Baths, Steam Heated

The »BHKD..BAL« version is suitable for spherical vessels with sealed in seat for a »BAL40« bottom outlet valve, the »BHKD..E« version for spherical vessels with extended bottom outlet (please see page 4.5).

The maximum permissible steam pressure in the heating coils is 10 bar g.

If required, a steam control valve, flexible hose and condensate separator can be supplied with these heating baths.

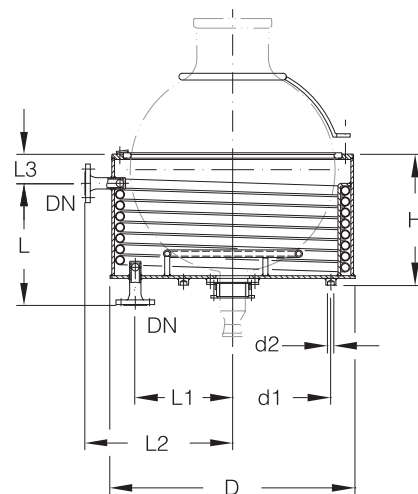

Nominal capacity of spherical vessel (l)	DN	D	d1	d2	L	L1	L2	L3	H	Reference with VS...E	Reference with VS...BAL
20	15	490	295	3 x 20	255	215	310	65	270	BHKD20E	BHKD20BAL
50	15	625	395	3 x 20	305	280	380	85	340	BHKD50E	BHKD50BAL
100	25	730	585	3 x 20	365	290	440	85	390	BHKD100E	BHKD100BAL
200	25	910	585	3 x 20	450	400	530	90	480	BHKD200E	BHKD200BAL

HEATING BATHS FOR SPHERICAL VESSELS

Heating Baths, Electrically Heated

As a standard these baths are supplied with either non hazardous or hazardous area immersion heating elements. As a consequence of the lower permissible surface temperature of the latter their heat output is lower. The supply voltage is 230/400 V, 3ph, 50 Hz in both cases.

Heating baths with hazardous area immersion heating elements are fitted with a level control.

The »BHKE..BAL« and »BHKX..BAL« versions are suitable for spherical vessels with sealed in seat for a »BAL40« bottom outlet valve, the »BHKE..E« and »BHKX..E« versions for spherical vessels with extended bottom outlet (please see page 4.5).

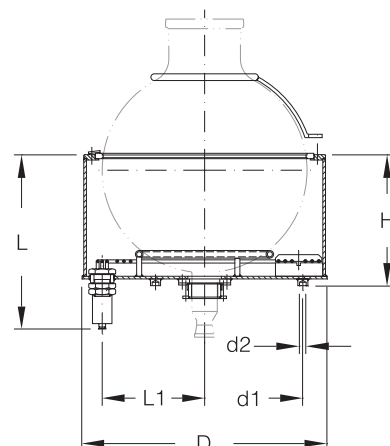

Non hazardous area immersion heating elements

Nominal capacity of spherical vessel (l)	D	d1	d2	L	L1	H	Power (kW)	Reference with VS...E	Reference with VS...BAL
20	490	295	3 x 20	400	183	270	3,6	BHKE20E	BHKE20BAL
50	625	395	3 x 20	470	250	340	6,0	BHKE50E	BHKE50BAL
100	730	585	3 x 20	520	305	390	9,0	BHKE100E	BHKE100BAL
200	910	585	3 x 20	610	395	480	11,0	BHKE200E	BHKE200BAL

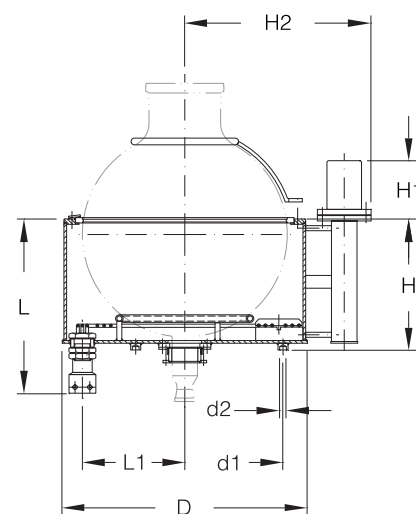

EEx de IIC T3 protection type immersion heating elements

Nominal capacity of spherical vessel (l)	D	d1	d2	L	L1	H	H1	H2	Power (kW)	Reference with VS...E	Reference with VS...BAL
20	490	295	3 x 20	530	170	270	155	435	3,8	BHKX20E	BHKX20BAL
50	625	395	3 x 20	600	237	340	155	505	6,0	BHKX50E	BHKX50BAL
100	730	585	3 x 20	650	290	390	155	555	9,0	BHKX100E	BHKX100BAL
200	910	585	3 x 20	740	380	480	155	645	11,4	BHKX200E	BHKX200BAL

STIRRER DRIVES

We can supply a range of drive assemblies for mixing, homogenising etc. using corrosion resistant stirrers (please see pages 4.43 to 4.45). They comprise various types of drive unit and stirrers of the appropriate shaft diameter in PTFE-sheathed or glass coated steel and borosilicate glass 3.3 (or stainless steel on request). The actual stirrer selected depends on the intended duty.

A selection of possible combinations of vessel, covers or adaptor flanges, stirrers and drives can be found in the tables below. The selection of a suitable combination of stirrer and drive power relates to materials of low to medium viscosities.

Stirrer Drives for Glass Vessels

Spherical Vessel with Reducer

Nom. cap. (l)	Vessel and Reducer	Stirrer	Stirrer Drive
10	VSM10 and PR100/50	SPG90/620	RAK50/034 or FAK50/037
20	VSM20 and PR100/50	SPG90/700	RAK50/034 or FAK50/037
50	VSM50 and PR200/50	SPG140/820	RAK50/034 or FAK50/037

Spherical Vessel with Cover Plate

Nom. cap. (l)	Vessel and Plate	Stirrer	Stirrer Drive
50	VSM50 and TFR200/80	STT140/700 or SPT145/690	RAL80/035 or FAL80/035
100	VSM100 and TFR200/80	STT140/800 or SPT145/790	RAL80/055 or FAL80/055
100	VSM100 and TFR200/100	STT140/800 or SPT145/790	RAL100/075 or FAL100/075

Cylindrical Vessel with Cover

Nom. cap. (l)	Vessel and Cover	Stirrer	Stirrer Drive
10	VZ10/200 and VZC200/50	SPG90/700	RAK50/034 or FAK50/037
20	VZ20/300 and VZME300/50	SPG140/700	RAK50/034 or FAK50/037
	VZ20/300 and VZC300/50		
	VZ20/300 and VZMC300/50		
30	VZ30/300 and VZME300/50	SPG140/820	RAK50/034 or FAK50/037
	VZ30/300 and VZC300/50		
	VZ30/300 and VZMC300/50		
50	VZ50/300 and VZME300/50	SPG140/1000	RAK50/034 or FAK50/037
	VZ50/300 and VZC300/50		
	VZ50/300 and VZMC300/50		
50	VZ50/300 and VZA300/80	STT140/1080 or SPT 145/1070	RAL80/035 or FAL80/035
	VZ50/300 and VZC300/80		
	VZ50/300 and VZMC300/80		
100	VZN100/450 and VZMC450/80	STT140/1080 or SPT145/1070	RAL80/055 or FAL80/055
	VZN100/450 and VZMC450/100	STT140/1080 or SPT145/1070	RAL100/075 or FAL100/075
150	VZN150/450 and VZMC450/100	STT140/1380 or SPT190/1370	RAL100/075 or FAL100/075

STIRRER DRIVES

Stirrer Drives for Glass-Lined Reaction Vessels

Nom. cap. (l)	Reaction Vessel	Stirrer	Stirrer Drive
25	VER25 or VERI25	SIE230/820	RAL80/055 or FAL80/055
40	VER40 or VERI40	SIE230/950	RAL80/055 or FAL80/055
63	VER63 or VERI63	SIE230/985	RAL80/055 or FAL80/055
100	VER100 or VERI100	SIE230/1020	RAL100/075 or FAL100/075
25	VER25 or VERI25	SAE335/820	RALA80/075 or FALA80/075
40	VER40 or VERI40	SAE335/950	RALA80/075 or FALA80/075
63	VER63 or VERI63	SAE385/985	RALA80/075 or FALA80/075
100	VER100 or VERI100	SAE500/1020	RALA100/110 or FALA100/110



In addition to the electrically operated drives shown, we are also able to supply pneumatically operated stirrer drives on request.

The stirrer drives except types »RAK..« and »FAK..« are fitted with anti-vibration mountings to avoid transmission of vibration from the motor to the structure and from there to the glass plant. They are fitted to the bearing housing (up to a power rating of 0.75 kW) or between the stirrer drive and the base plate.

The gasket, backing flange and fixings are included in the supply.

STIRRER DRIVES

Variable Speed Drive Assemblies with Bearing Assembly

These assemblies incorporate a flange-mounted bearing assembly. This is fitted below a variable speed drive motor and facilitates direct mounting of the complete drive unit onto a glass vessel cover. The drive spindle and stirrer shaft are connected inside the housing by means of a clamp type coupling for smaller drives or muff type for larger drives.

In order to meet the stirring duty, the speed can be varied from 0 up to the respective maximum via a manual hand wheel for these drive types. The setting can be changed with the drive stopped or in operation. Before switching on the drive motor it should be set to its lowest speed.

As standard, electric motors are manufactured to protection type EEx e II T4 and EEx de IIC T4, and for voltage connections of 230/400V, 3 phase, 50 Hz.

To facilitate supporting the drive unit in the structure, structure fittings and tubular structures can be used (please see Section 10 »Structures & Supports«). They are not included in the supply.

These stirrer drive units are designed for use with PTFE, glass coated steel and stainless steel stirrers with a shaft diameter of 44.5 mm.

ATEX Version with Single-Acting Mechanical Seal

Protection Type II 1/2 G c b II T4

The stirrers (suffix ..SAT) with single-acting mechanical seals are approved for operations within zone 0 (category 1) inside the vessel, and for zone 1 (category 2) outside the vessel in accordance with EU directive 94/9/EG (ATEX).

The mechanical seals operate on a SIC/hard-carbon sealing surface, and conform to FDA requirements. An integrated-temperature measuring device built into the sealing plate, which is a requirement for regulation-conform operations, monitors the maximum temperature within the mechanical seal. For use within the temperature class T4, the temperature rating is 100°C, for T3 it is 150°C.

ATEX Version with Double Mechanical Seal

Protection Type II 1/2 G c b II T4

The stirrers (suffix ..AT) with double acting fluid-lubricant mechanical seals are approved for operations within zone 0 (category 1) inside the vessel, and for zone 1 (category 2) outside the vessel in accordance with EU directive 94/9/EG (ATEX).

The mechanical seal operates on a PTFE/ceramic sealing surface.

The installation of a cooled lubricant circulation is required to conform to regulations and for which the sealing liquid level within the vessel and the sealing media temperature (as measured within the mechanical seal casing) shall be monitored, contingent to the above rating.

Temperature monitoring may be omitted if the stirrer is only deployed within zone 1 (category 2) inside the vessel.

If the maximum sealing media temperature is held at 50°C, use is possible at product temperatures ranging up to 200°C. If used at temperature class T4, the maximum product temperature shall not exceed 108°C; for T3, it shall not exceed 160°C.

The length L of the stirrer is extended by 90 mm compared to the single-action mechanical seal, along with the overall length for the drive.

Version with Single-Action, non ATEX Mechanical Seal

The stirrer version with single-action mechanical seal that does not conforming to ATEX operates on PTFE/ceramic sealing surface, which has proven itself in many years of use.

The operating temperature is limited to 120°C.

DRIVES WITH VARIABLE SPEED

Motor protection type EEx e II T4

DN	d	d1	D2	H	H1	H2	H3	Power (kW)	Speed (min ⁻¹)	Reference
80	44,5	2 x M10	138	730	138	153	298	0,50	0-800	RAL80/035
80	44,5	2 x M10	156	800	138	153	298	0,55	0-600	RAL80/055
100	44,5	2 x M10	156	800	138	153	298	0,65	0-600	RAL100/075
80	44,5	2 x M10	156	945	138	153	298	0,65	0-240	RALA80/075
100	44,5	2 x M10	176	990	138	153	298	1,35	0-240	RALA100/110

Protection type EEx de IIC T4

DN	d	d1	D2	H	H1	H2	H3	Power (kW)	Speed (min ⁻¹)	Reference
80	44,5	2 x M10	138	770	138	153	298	0,55	0-800	FAL80/035
80	44,5	2 x M10	156	840	138	153	298	0,55	0-600	FAL80/055
100	44,5	2 x M10	156	840	138	153	298	0,75	0-600	FAL100/075
80	44,5	2 x M10	156	990	138	153	298	0,75	0-240	FALA80/075
100	44,5	2 x M10	176	1005	138	153	298	1,50	0-240	FALA100/110

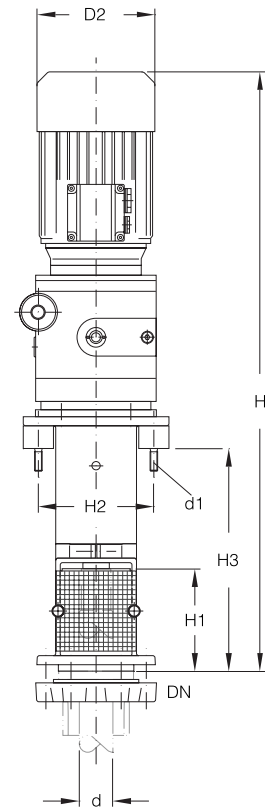

ATEX VERSION WITH DRY RUNNING MECHANICAL SEAL

Protection Type II 1/2 G cb II T4

DN	d	d1	D2	H	H1	H2	H3	Power (kW)	Speed (min ⁻¹)	Reference
80	44,5	2 x M10	138	730	138	153	298	0,50	0-800	RAL80/035/SAT
80	44,5	2 x M10	156	800	138	153	298	0,55	0-600	RAL80/055/SAT
100	44,5	2 x M10	156	800	138	153	298	0,65	0-600	RAL100/075/SAT
80	44,5	2 x M10	156	945	138	153	298	0,65	0-240	RALA80/075/SAT
100	44,5	2 x M10	176	990	138	153	298	1,35	0-240	RALA100/110/SAT

Protection Type II 1/2 G cb II T4

DN	d	d1	D2	H	H1	H2	H3	Power (kW)	Speed (min ⁻¹)	Reference
80	44,5	2 x M10	138	770	138	153	298	0,55	0-800	FAL80/035/SAT
80	44,5	2 x M10	156	840	138	153	298	0,55	0-600	FAL80/055/SAT
100	44,5	2 x M10	156	840	138	153	298	0,75	0-600	FAL100/075/SAT
80	44,5	2 x M10	156	990	138	153	298	0,75	0-240	FALA80/075/SAT
100	44,5	2 x M10	176	1005	138	153	298	1,50	0-240	FALA100/110/SAT

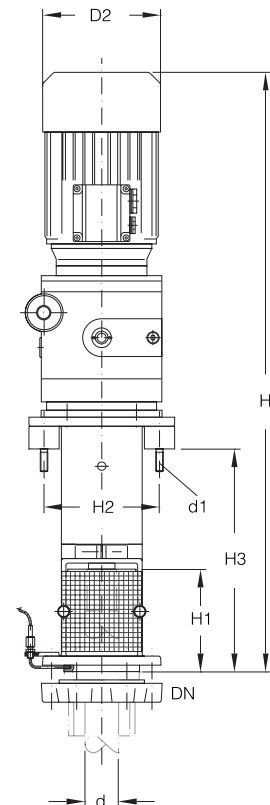

ATEX VERSION WITH DOUBLE ACTING MECHANICAL SEAL

Protection type II 1/2 G cb II T4

DN	d	d1	D2	H	H1	H2	H3	Power (kW)	Speed (min ⁻¹)	Reference
80	44,5	2 x M10	138	816	234	153	393	0,50	0-800	RAL80/035/AT
80	44,5	2 x M10	156	886	234	153	393	0,55	0-600	RAL80/055/AT
100	44,5	2 x M10	156	886	227	153	386	0,65	0-600	RAL100/075/AT
80	44,5	2 x M10	156	1034	234	153	393	0,65	0-240	RALA80/075/AT
100	44,5	2 x M10	176	1078	227	153	386	1,3	0-240	RALA100/110/AT

Protection type II 1/ 2 G cb II T4

DN	d	d1	D2	H	H1	H2	H3	Power (kW)	Speed (min ⁻¹)	Reference
80	44,5	2 x M10	138	862	234	153	393	0,55	0-800	FAL80/035/AT
80	44,5	2 x M10	156	933	234	153	393	0,55	0-600	FAL80/055/AT
100	44,5	2 x M10	156	926	227	153	386	0,75	0-600	FAL100/075/AT
80	44,5	2 x M10	156	1081	234	153	393	0,75	0-240	FALA80/075/AT
100	44,5	2 x M10	176	1114	227	153	386	1,5	0-240	FALA100/110/AT

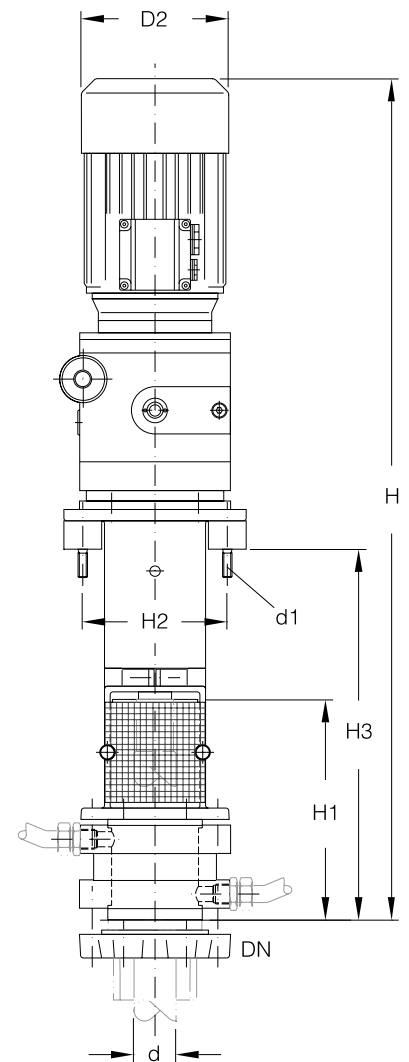

DRIVES WITH FREQUENCY CONVERTERS

Drives for Frequency Inverter

This type of drive can be used whenever variations in speed are achieved by means of a frequency inverter. The flameproof electric motor is fitted with the required thermistors as standard. These drives can also be used to drive stirrers at a fixed speed (750 rpm), this can however cause problems on start-up. Such a solution should, therefore, only be adopted in exceptional cases.

The drive shaft and stirrer blade are also connected to each other via a clamp coupling within the lantern, just as the variants with gear motor.

The electric motors, which have a minimum speed of 75 rpm, are supplied with protection type EEx de IIC T4 and for a 230/400 V, 3 phase, 50 Hz supply. It shall be observed that the small torque available at low turning speed can lead to difficulties for tough media or tasks.

These stirrer drive units are designed for use with PTFE, enamelled steel and stainless steel (on request only) stirrers with a 44.5 mm shaft diameter.

ATEX Version with Single-Acting Mechanical Seal

Protection Type II 1/2 G c b II T4

The stirrers (suffix ..SAT) with a single-acting mechanical seal are approved for use in zone 0 (category 1) inside the vessel, and zone 1 (category 2) outside the vessel in accordance with EU directive 94/9/EG (ATEX).

The mechanical seal operates on a SiC/hard-carbon sealing surface, and is conform to FDA requirements. The maximum temperature within the mechanical seal is monitored by an integrated temperature measurement device within the sealing plate, which is a requirement for regulation-conforming operations.

The temperature rating is 100°C for use in temperature class T4; for T3 it is 150°C.

ATEX Version with Double Mechanical Seal

Protection Type II 1/2 G c b II T4

The stirrers (suffix ..AT) with a double acting mechanical seal are approved for use in zone 0 (category 1) inside the vessel, and zone 1 (category 2) outside the vessel in accordance with EU directive 94/9/EG (ATEX).

The mechanical seal operates on a PTFE/ceramic sealing surface.

The installation of a cooled lubricant circulation is required to conform to regulations and for which the sealing liquid level within the vessel and the sealing media temperature (as measured within the mechanical seal casing) shall be monitored, contingent to the above rating.

Temperature monitoring may be omitted if the stirrer is only deployed within zone 1 (category 2) inside the vessel.

If the maximum sealing media temperature is held at 50°C, use is possible at product temperatures ranging up to 200°C. If used at temperature class T4, the maximum product temperature shall not exceed 108°C; for T3, it shall not exceed 160°C.

The length of the stem is extended by 90 mm compared to the single-action mechanical seal, along with the overall length for the drive.

Version with Single-Action, non ATEX Mechanical Seal

The stirrer version with single-action mechanical seal that does not conforming to ATEX operates on PTFE/ceramic sealing surface, which has proven itself in many years of use.

The operating temperature is limited to 120°C.

DRIVES FOR FREQUENCY CONVERTERS

Motor protection type .EEx e II T4

DN	d	d1	D2	H	H1	H2	H3	Power (kW)	Speed with Freq. Inverter (min-1)	Reference
80	44,5	2 x M10	188	680	138	153	298	0,37	75-750	RAE80/037
80	44,5	2 x M10	188	680	138	153	298	0,55	75-750	RAE80/055
80	44,5	2 x M10	206	725	138	153	298	0,75	75-750	RAE80/075
100	44,5	2 x M10	188	673	138	153	298	0,37	75-750	RAE100/037
100	44,5	2 x M10	188	673	138	153	298	0,55	75-750	RAE100/055
100	44,5	2 x M10	206	725	138	153	298	0,75	75-750	RAE100/075
100	44,5	2 x M10	206	725	138	153	298	1,10	75-750	RAE100/110

ATEX Version with Dry Running Mechanical Seal

Protection type .II 1/2 G cb II T4

DN	d	d1	D2	H	H1	H2	H3	Power (kW)	Speed with Freq. Inverter (min-1)	Reference
80	44,5	2 x M10	188	680	138	153	298	0,37	75-750	RAE80/037/SAT
80	44,5	2 x M10	188	680	138	153	298	0,55	75-750	RAE80/055/SAT
80	44,5	2 x M10	206	725	138	153	298	0,75	75-750	RAE80/075/SAT
100	44,5	2 x M10	188	680	138	153	298	0,37	75-750	RAE100/037/SAT
100	44,5	2 x M10	188	680	138	153	298	0,55	75-750	RAE100/055/SAT
100	44,5	2 x M10	206	725	138	153	298	0,75	75-750	RAE100/075/SAT
100	44,5	2 x M10	206	725	138	153	298	1,10	75-750	RAE100/110/SAT

ATEX Version with Double Acting Mechanical Seal

Protection type .II 1/2 G cb II T4

DN	d	d1	D2	H	H1	H2	H3	Power (kW)	Speed with Freq. Inverter (min-1)	Reference
80	44,5	2 x M10	188	770	230	153	388	0,37	75-750	RAE80/037/AT
80	44,5	2 x M10	188	770	230	153	388	0,55	75-750	RAE80/055/AT
80	44,5	2 x M10	206	815	230	153	388	0,75	75-750	RAE80/075/AT
100	44,5	2 x M10	188	770	230	153	388	0,37	75-750	RAE100/037/AT
100	44,5	2 x M10	188	770	230	153	388	0,55	75-750	RAE100/055/AT
100	44,5	2 x M10	206	815	230	153	388	0,75	75-750	RAE100/075/AT
100	44,5	2 x M10	206	815	230	153	388	1,10	75-750	RAE100/110/AT

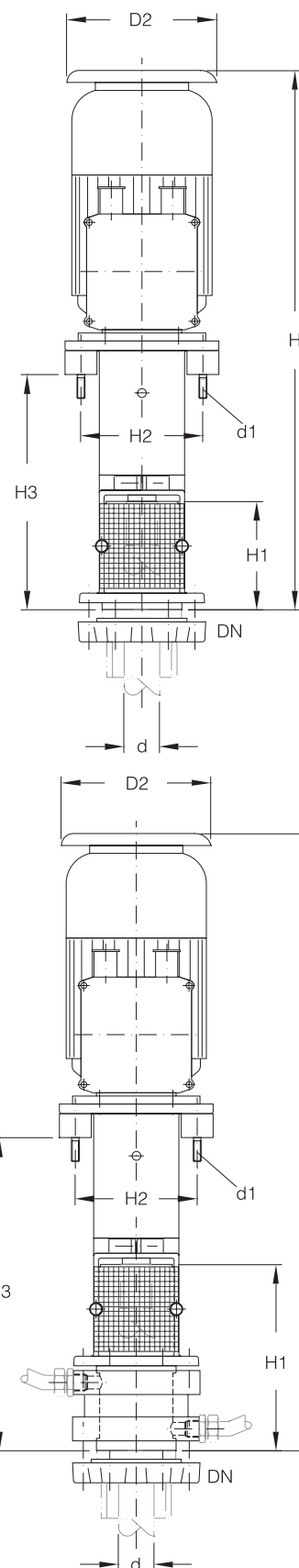

STIRRER DRIVES FOR GLASS STIRRERS

Compact Variable Speed Drives

These assemblies incorporate a variable speed drive motor and a closed housing suitable for mounting directly onto a vessel cover. The motor spindle and stirrer shaft are connected together with grub screws. The single acting mechanical seal is located in the housing. These are both easily accessible after removing the drive motor. An opening is provided on the housing so that the rotating part of the mechanical seal can be locked in position on the stirrer shaft.

On vessel covers, compact drives suitable for coupling to a DN 50 nominal size branch are used.

 These Stirrer Drive units are designed for use with borosilicate glass 3.3 stirrers with a 32 mm shaft diameter and a maximum length of 1000 mm (please see page 4.45). Their use is therefore restricted to a maximum stirred volume of 50 litres.

Electric motors are supplied as standard in protection type EEx e II T4 or EEx de IIC T4 and for a 230/400 V, 3 phase, 50 Hz supply. Other voltages and frequencies can also be catered for. The stirrer drive is not certified in accordance with ATEX.

The maximum allowable operating temperature for the single acting mechanical seal is 120 °C.

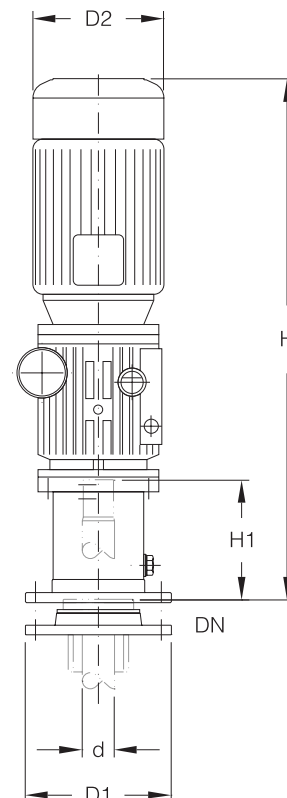

Protection type EEx e II T4

DN	d	D1	D2	H	H1	Power (kW)	Speed (min ⁻¹)	Reference
50	32	145	145	517	119	0,34	0-550	RAK50/034

Protection type EEx de IIC T4

DN	d	D1	D2	H	H1	Power (kW)	Speed (min ⁻¹)	Reference
50	32	145	150	543	119	0,37	0-550	FAK50/037

THERMOSIPHON UNITS

These units work on the thermosiphon principle. We always recommend using them in conjunction with double mechanical seals whenever handling substances that are toxic or highly corrosive, that contain abrasive components or that have a tendency to crystallise. The barrier fluid, which should be chosen on the basis of its compatibility with the product, carries out three functions necessary for trouble-free operation: it acts as a barrier, provides lubrication and keeps the unit cool. It is covered by a gas buffer, pressurised to suit the operating pressure in the reaction vessel.

Thermosiphon units are supplied with or without a top-up unit to maintain the barrier fluid level during operation. This cannot be retrofitted.

Type »THAO..« (without top-up unit) comprises a vessel with an internally fitted cooling coil in stainless steel, pressure gauge and sight glass together with the fittings necessary for connection to the mechanical seal including 4 m stainless-steel clad hose. Type »THAP..« (with top-up unit) comprises the same items plus an additional vessel and a built-on hand-pump. The parts in contact with the product are also made of stainless steel.

 If stirrer drives are used with siphon systems in areas with danger of explosion within the European Union ATEX, the siphon vessel must be monitored for a minimum fill level using a fill-level probe in accordance with EU directive 94/9/EC (ATEX). If you select the order number ending AT, then you will receive the siphon vessel with an integrated fill-level probe.

Technical data

Reference		THAO3	THAO6	THAP3	THAP6
		THAO/AT	THAO6/AT	THAP3/AT	THAP6/AT
Tank Capacity	l	3	6	3	6
Nominal Capacity	l	2,5	4	2,5	4
Heat Transfer Area of the Cooling Coil	m ²	0,1	0,14	0,1	0,14

Tank Capacity (l)	D	d1	B	H	E	E1	E2	Type	Reference without ATEX	Reference with ATEX
3	140	M10	-	475	95	292	60	A	THAO3	THAO3/AT
6	170	M10	-	550	110	292	60	B	THAO6	THAO6/AT
3	140	M10	230	475	95	292	60	A	THAP3	THAP3/AT
6	170	M10	260	550	110	292	60	B	THAP6	THAP6/AT

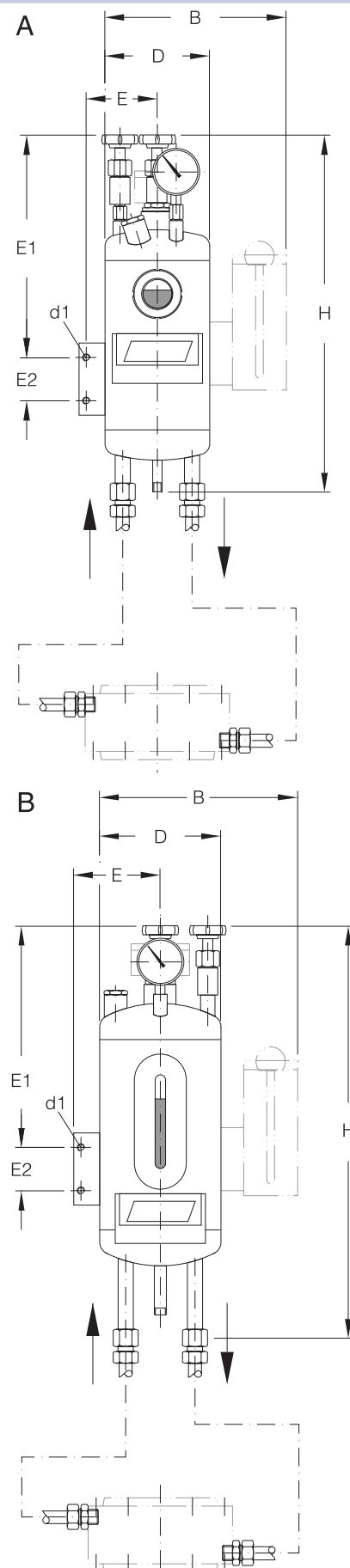

CONNECTING FLANGES FOR STIRRERS

Where space is limited or, if for other reasons, there is no need to fit a vessel cover (please see pages 4.18 to 4.20) with its various branches, the stirrer drives described above, with the exception of types »RAK..« and »FAK..«, can also be mounted directly onto spherical vessels (please see pages 4.5 to 4.8) by means of these connecting flanges. They are stainless steel rings which are PTFE-sheathed in the area in contact with the product and are available as standard for DN 200 and DN 300 branches. No additional gaskets are required.

 The adaptor flange, insert and fixings are included in the supply.

DN	DN1	D	D1	L	Reference
200	80	321	76	19	TFR200/80
200	100	321	104	19	TFR200/100
300	80	428	76	19	TFR300/80
300	100	428	104	19	TFR300/100

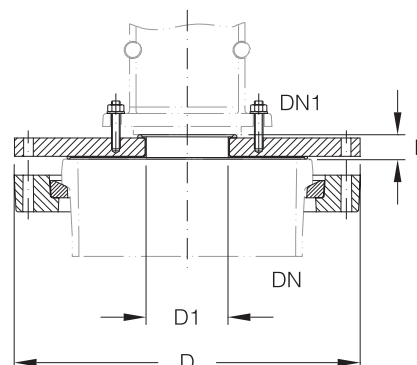

PTFE STIRRERS

The different shapes of vessel (spherical or cylindrical vessels) on the one hand and the duties to be carried out on the other (suspension, homogenisation, with or without simultaneous heat transfer etc.) determine the type of stirrer to be used. Their design (propeller or turbine) is another factor influencing the need or otherwise for a baffle to create turbulence. Further information can be found with the individual types of stirrer.

These two-piece stirrers consist of a PTFE-sheathed shaft and a PTFE stirrer element with steel core that is attached to the shaft to prevent twisting. A perfect seal is maintained between the two parts over the whole permissible temperature range (-50 to +150 °C).

 The PTFE used in the manufacture of these stirrers is carbon filled.

Conductive material may be delivered upon request.

For construction reasons the maximum possible stirrer length is limited to 1800 mm.

PTFE STIRRERS

Propeller Stirrers

These stirrers produce axial primary flow with a radial component and are particularly suitable for homogenisation and suspension. They are also suitable for general stirring duties with simultaneous heat transfer (heating or cooling) between the liquid being stirred and the vessel wall. They can also be used for dispersion (including from gases) and emulsification.

Propeller stirrers are mainly used with borosilicate glass 3.3 spherical and cylindrical vessels. In the latter case it is recommended that they be installed on an eccentric stirrer branch to avoid setting up a vortex.

L	D	d1	Reference
690	145	44,5	SPT145/690
790	145	44,5	SPT145/790
1070	145	44,5	SPT145/1070
1370	190	44,5	SPT190/1370

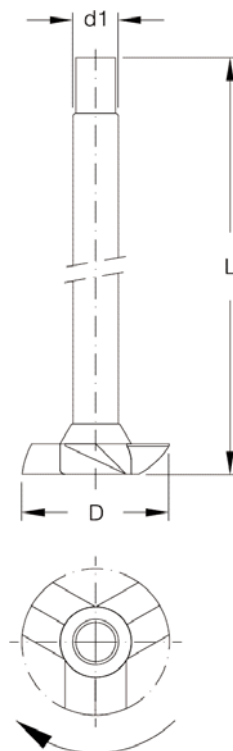

PTFE STIRRERS

Turbine Stirrers

These stirrers produce a radial primary flow and are recommended for homogenisation, dispersion (including from gases) and emulsification. They can also be used when heat transfer between the liquid being stirred and the vessel wall is required.

Turbine stirrers are mainly used with borosilicate glass 3.3 spherical vessels and cylindrical vessels. In the latter case it is recommended that they be installed on an eccentric stirrer branch to avoid setting up a vortex.

L	D	d1	Reference
700	140	44,5	STT140/700
800	140	44,5	STT140/800
1080	140	44,5	STT140/1080
1380	140	44,5	STT140/1380

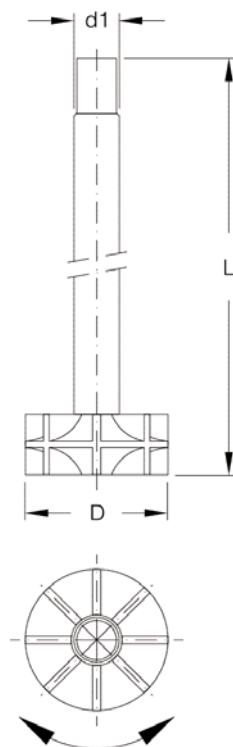

GLASS COATED STEEL STIRRERS

We supply one-piece impeller and anchor type glass coated steel stirrers with a 44.5 mm shaft diameter for use with the glass lined steel reaction vessels described on pages 4.23 and 4.24.

 When these stirrers are used the drive power required needs to be assessed. We would be happy to do this for you.

Impeller Stirrers

These stirrers generate a radial primary flow and are used mainly for homogenising high viscosity liquids. They are also ideally suited for applications where good heat transfer is required between the liquid being stirred and the vessel wall. Impeller stirrers are used with types »RAL..«, »FAL..« and »RAE..« stirrer drive units (please see pages 4.38 and 4.39).

L	D	d1	Reference
820	230	44.5	SIE230/820
950	230	44.5	SIE230/950
985	230	44.5	SIE230/985
1020	230	44.5	SIE230/1020

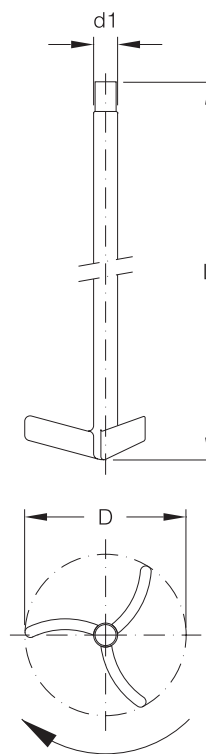

GLASS COATED STEEL STIRRERS

Anchor Stirrers

These are used for applications involving relatively low speeds at the circumference and where higher viscosities may be encountered. They are particularly suitable for homogenisation with simultaneous heat transfer between the liquid being stirred and the vessel wall. Anchor stirrers are used with types »RALA..« and »FALA..« stirrer drive units (please see page 4.38).

L	D	d1	Reference
820	335	44,5	SAE335/820
950	335	44,5	SAE335/950
985	385	44,5	SAE385/985
1020	500	44,5	SAE500/1020

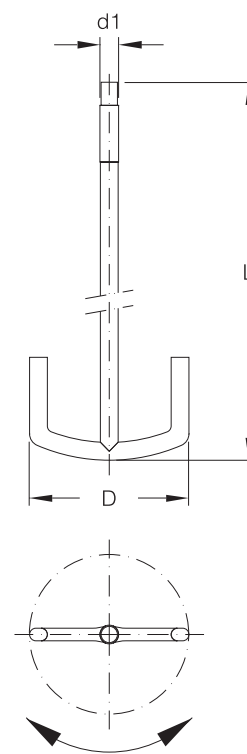

GLASS STIRRERS

It is possible to produce propeller and vortex type stirrers in borosilicate glass 3.3 with its almost universal resistance to corrosion.

All glass stirrers have a 32 mm shaft diameter and can be used with the »RAK.« and »FAK.« type stirrer drives (as described on page 4.42).

GLASS STIRRERS

Propeller Stirrers

As a result of the axial primary flow these stirrers produce, there is a very wide range of applications for them. They are used for homogenisation, dispersion (also from gases) and emulsification and they can also be used on a restricted basis for suspensions. Another application for them is for stirring with simultaneous heat transfer (heating or cooling) between the liquid being stirred and the vessel wall.

L	D	d1	Reference
620	90	32	SPG90/620
700	90	32	SPG90/700
700	140	32	SPG140/700
820	140	32	SPG140/820
1000	140	32	SPG140/1000

